

ORIGAMI

30 FOLD-BY-FOLD PROJECTS



If you mention pizza to an Italian or samba to a Brazilian they will know instantly what you mean and it is the same if you say origami to the Japanese, they understand immediately that you are talking about the art of paperfolding.

They might even be so flattered by your interest in the subject that they would give you some tips on the craft. They may probably even fold a crane bird for you, which is the traditional Japanese model that many Japanese people can fold. However, just as nowadays pizza and the samba are not confined to their country of origin, origami is found not only in Japan but has also been introduced into many countries.

● If you are interested in finding out more about the history of paperfolding, you will come across two different traditions, that are believed to have developed independently of each other: an Asiatic

tradition with Chinese–Japanese origins and a European tradition which originated in Spain. The craft of origami as we know it today in the West began in the early 1950s in England, and contacts with Japan for a deeper knowledge of the art soon

inspired others to form a network of enthusiastic and creative paperfolders in Britain, the United States and Europe.

● Since I became deeply interested in the craft of origami, I have discovered that it involves not only folded paper figures but also the personalities and nimble fingers of their originators. ● I have traveled through many countries trying to trace these people and, in this book, I will present some of the models I came across during my trips.

● Folding brings opportunities for unfolding!

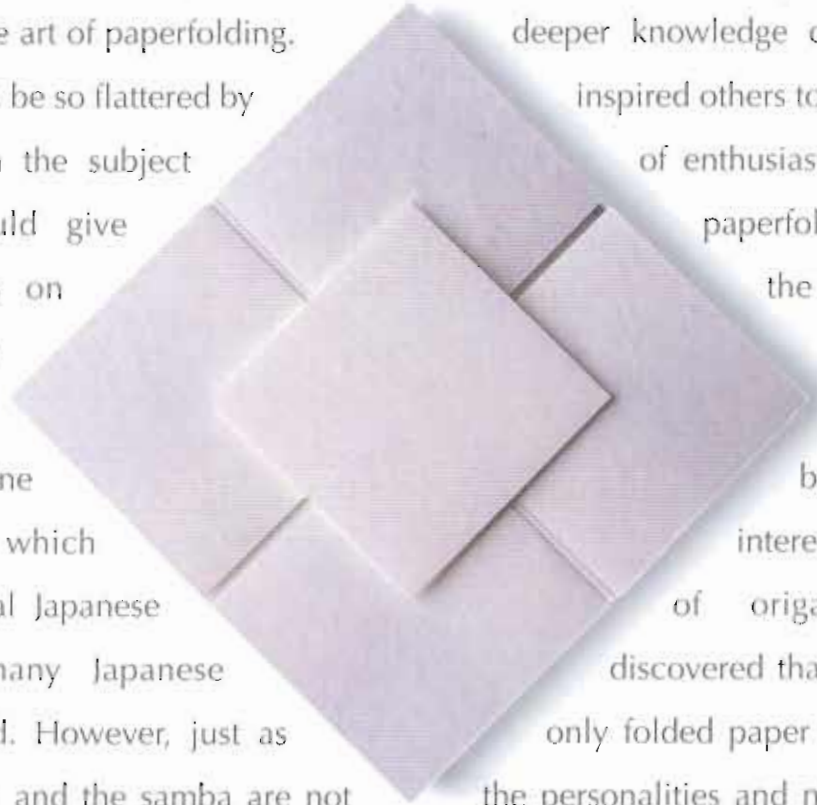

Paulo Mulatinho



Paulo Mulatinho

Origami

Origami

30-Fold-by-Fold
Projects

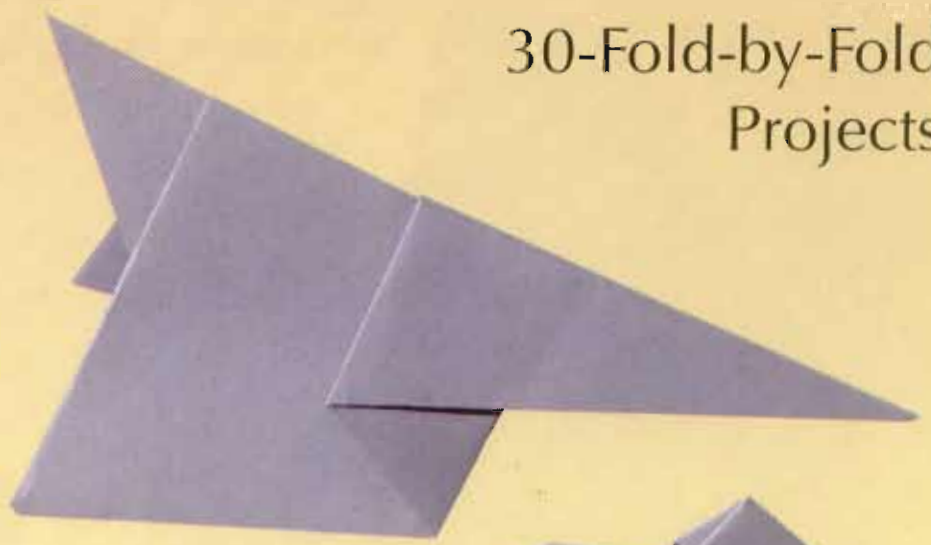

CHARTWELL
BOOKS, INC.



Contents

Material 5
Symbols 6

Simple and Amazing Models

Envelope 9
Crossed Box Pleat 10
Nose and Mustache 12
Paperholder 14
Double Hearts 16
Cup 19
The Shirt Off One's Back 20
Arrow 22
Object 23
Nun 24
Pipe 26

Origami Zoo

Shy Young Hare 30
Elephant 32
Frog 34
Mouse 36
Panda 38

For a Desk Top

Picture Frame 45
Note Book 48
Container 50
Folder 52
Daisy's Envelope 54

Presenting Gifts

Bowl 56
Gift Box 58

Christmas Decorations

Star 62
Angel 64
Decoration 66
Happy Santa 68

Geometric Figures

Cube 72
Open Cube 74
Sonobe Cube 76



What do I need for origami?

The answer is simple: just paper!

You can find paper just about anywhere in many different qualities and sizes. You can use any type of paper you like as long as it can be folded. One-colored or multicolored, thick or thin, smooth or rough, expensive or cheap, large or small — it all depends on your taste and the model you want to make.

You can use gift wrapping-paper, drawing-paper, writing-paper, parcel wrapping-paper, paper used for handicrafts, and so on. The only disadvantage of these types of papers is that you first have to cut them to the correct starting size for your model — in most cases a square, sometimes 11.6 x 8.25 in (29.7 x 21 cm). If you want to save yourself this chore, you should buy origami paper which comes in a square and is ideal for folding. Your local stationery or handicrafts shop will probably have a selection. I take a little pack of origami paper with me everywhere and am ready to start folding whenever the occasion presents itself.

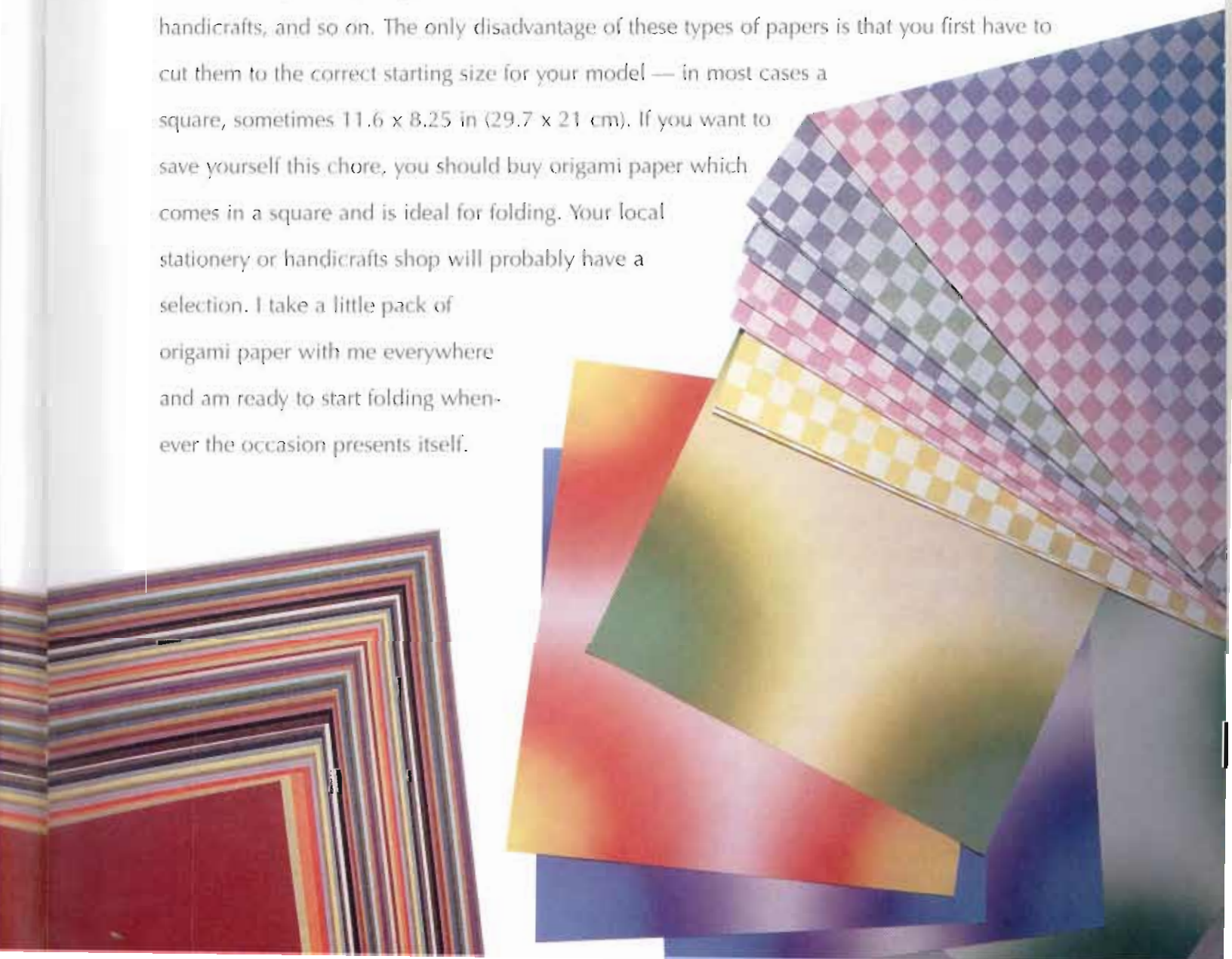

Symbols



Colored side down



Colored side up



Fold forward and backward



Turn over the model



The following drawing is shown to a larger scale



Open out the model at this point and fold it in the direction shown

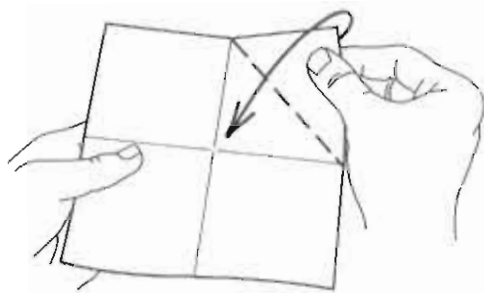

Folding is easy ...

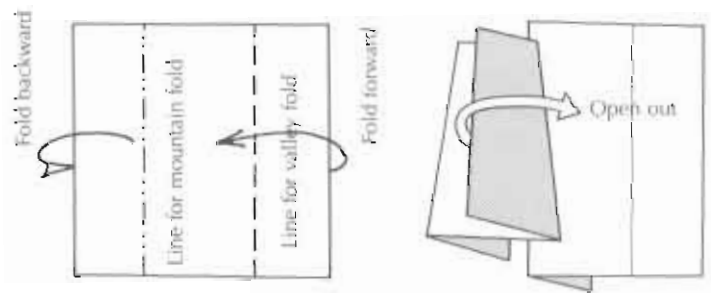

In the following instructions you will find all the information you need for folding a model set out in the form of drawings. Lines and arrows tell you what to do. Each of these internationally accepted symbols has its own meaning and is explained here. In the instructions themselves I have only added explanatory text where I considered it helpful, or to point out stages where things may possibly go wrong. Each individual step shows which fold should be made. The result of this fold is shown in the following drawing for the next step.

What makes a mountain fold and a valley fold depends on the viewing angle. Turning the paper over changes a valley fold into a mountain fold and vice versa.

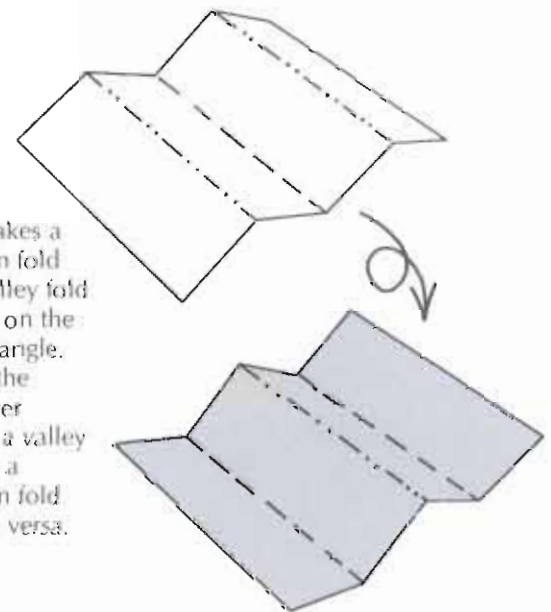

The instructions in this book, with the mountain and valley folds and the different types of arrows, constitute a kind of "language" between you and me: you would like to fold the model shown and I would like to explain the folding sequence to you by means of the drawings. Since we cannot hold a "true" dialogue, I hope that as few misunderstandings as possible will arise between us. However, if any do, the fault is certainly mine. I do realize that a set of instructions cannot be perfectly clear to everyone.

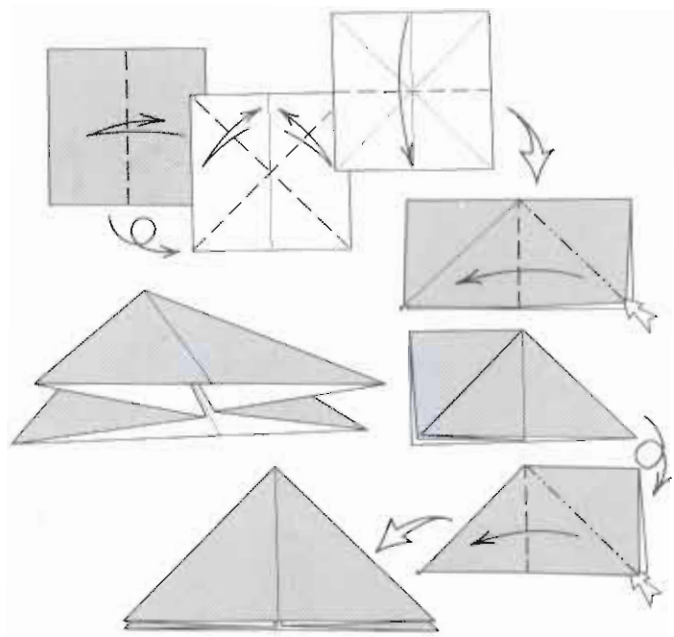

This is called the waterbomb base ...

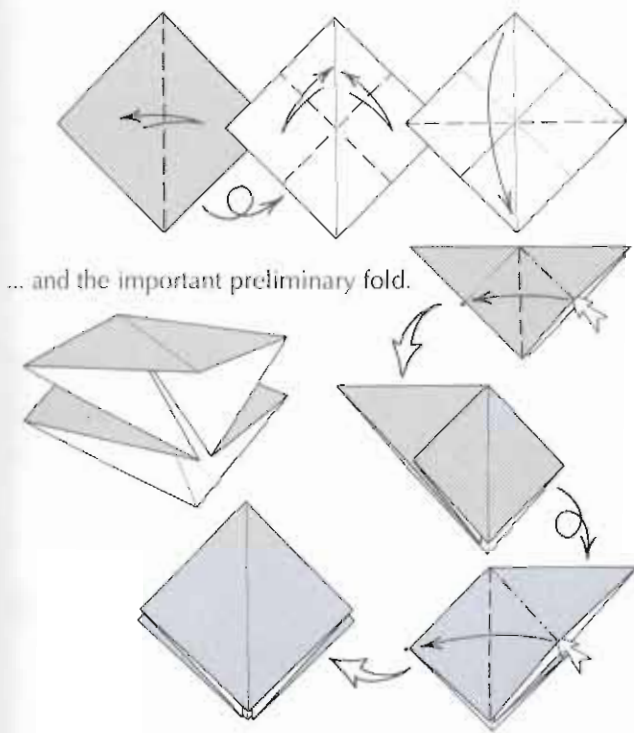

... and the important preliminary fold.

Beginners especially, who are not that familiar with the rather technical drawings, can easily get stuck during the folding, each one in a different place. Worrying over it just does not help. Put the paper aside, do something else for a while, and at a second attempt you will probably get the hang of it immediately. Do not worry about making mistakes, they can lead you to your goal.

Inside reverse fold ...

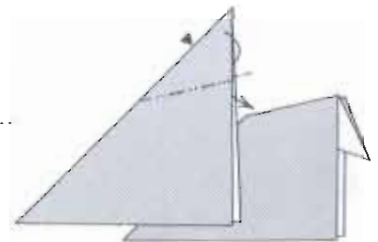

Simple and Amazing Models

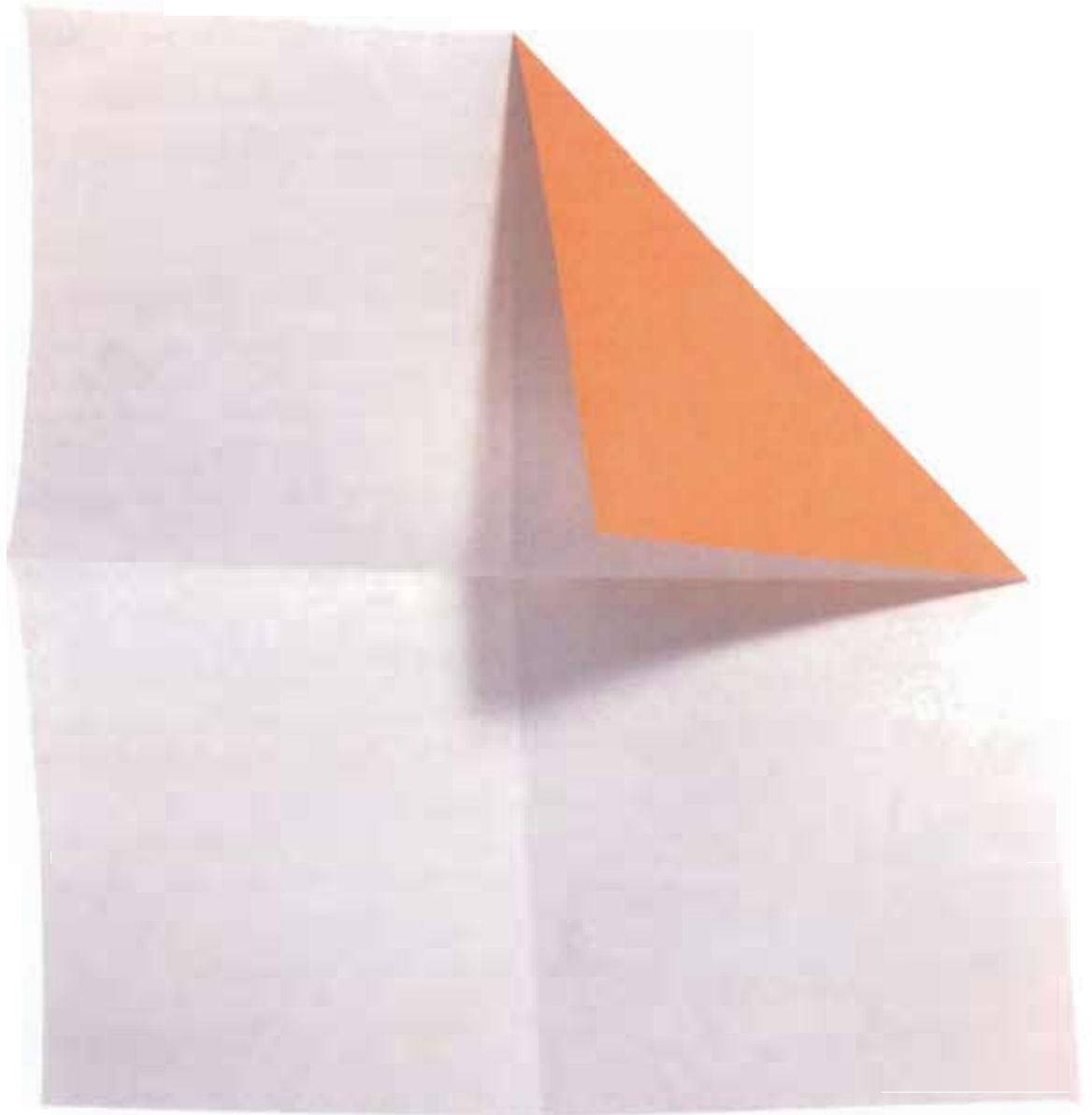

Envelope

TRADITIONAL

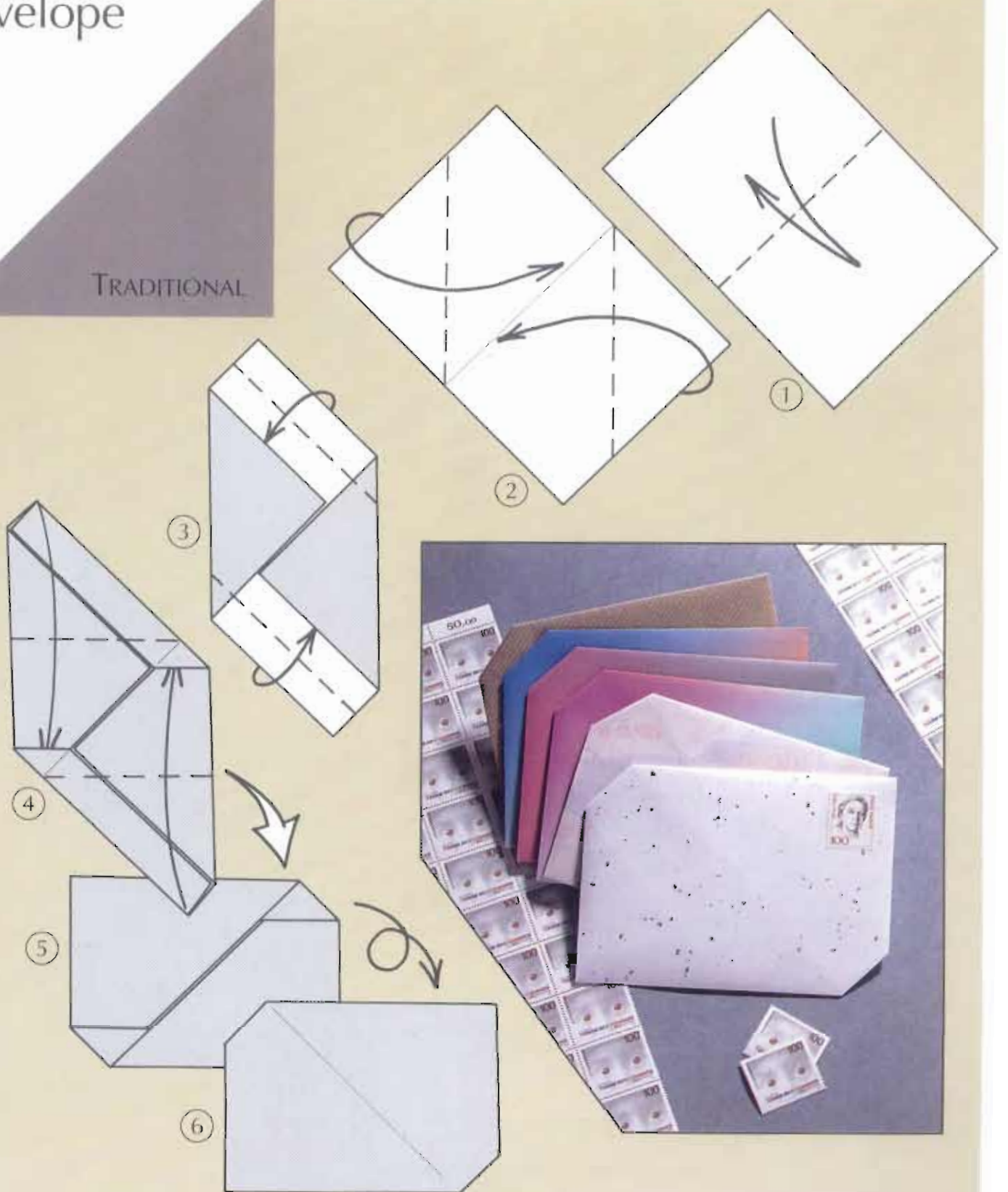

Crossed Box Pleat

THOKI YENN

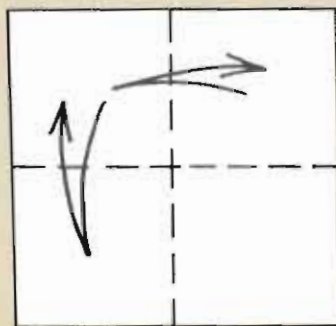

①

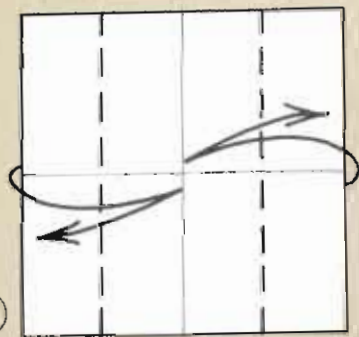

②

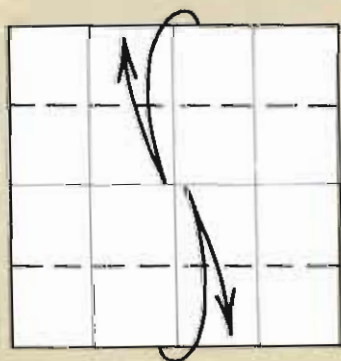

③

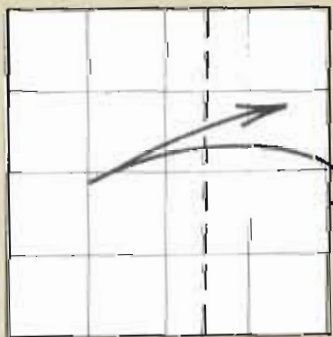

④

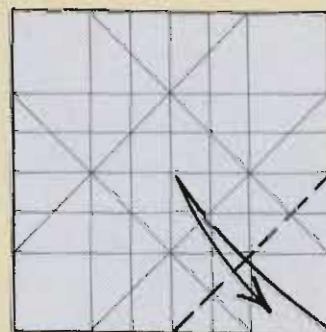

⑥

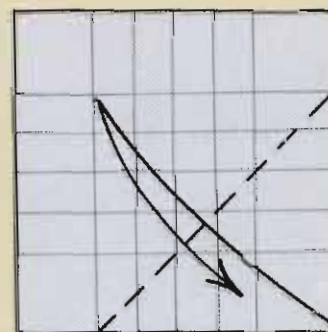

⑤

Repeat the folds shown in steps 4, 5 and 6 with the other three edges and corners respectively.

No new creases are being made in step 8, but the existing mountain as well as valley folds have to be creased again sharply. This will make it easier to push the parts together in the next steps.

8

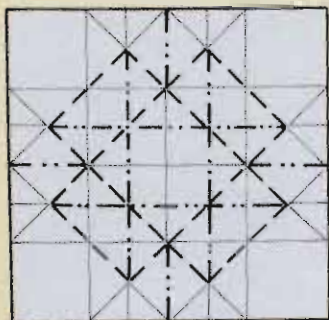

9

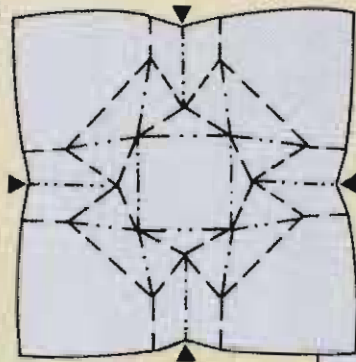

When pushing the edges together, make sure that the mountain and valley folds correspond to the ones in the drawing. Turn the model over after you have stressed the relief.

10

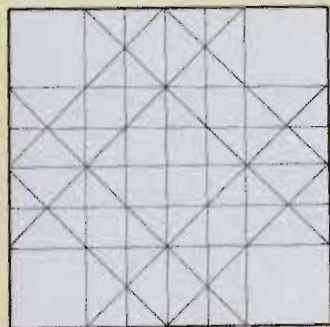
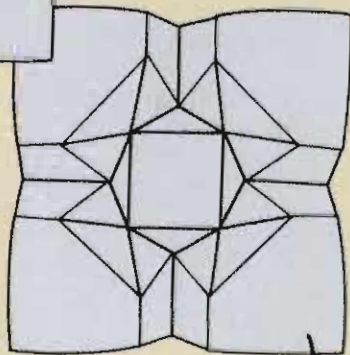

7

11



Push the parts together in the center and flatten the upstanding parts to the side.

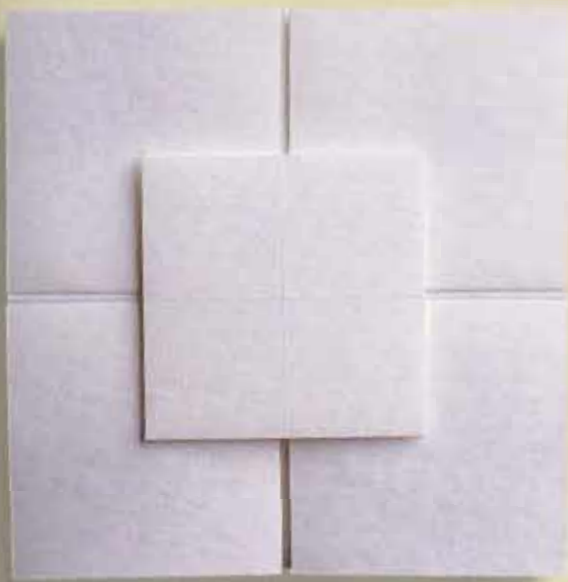

12

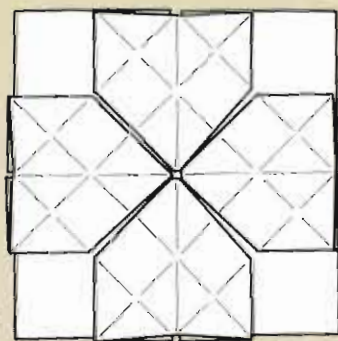

Seen from the bottom.

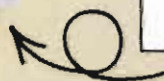

Nose and Mustache

GABRIEL ALVAREZ

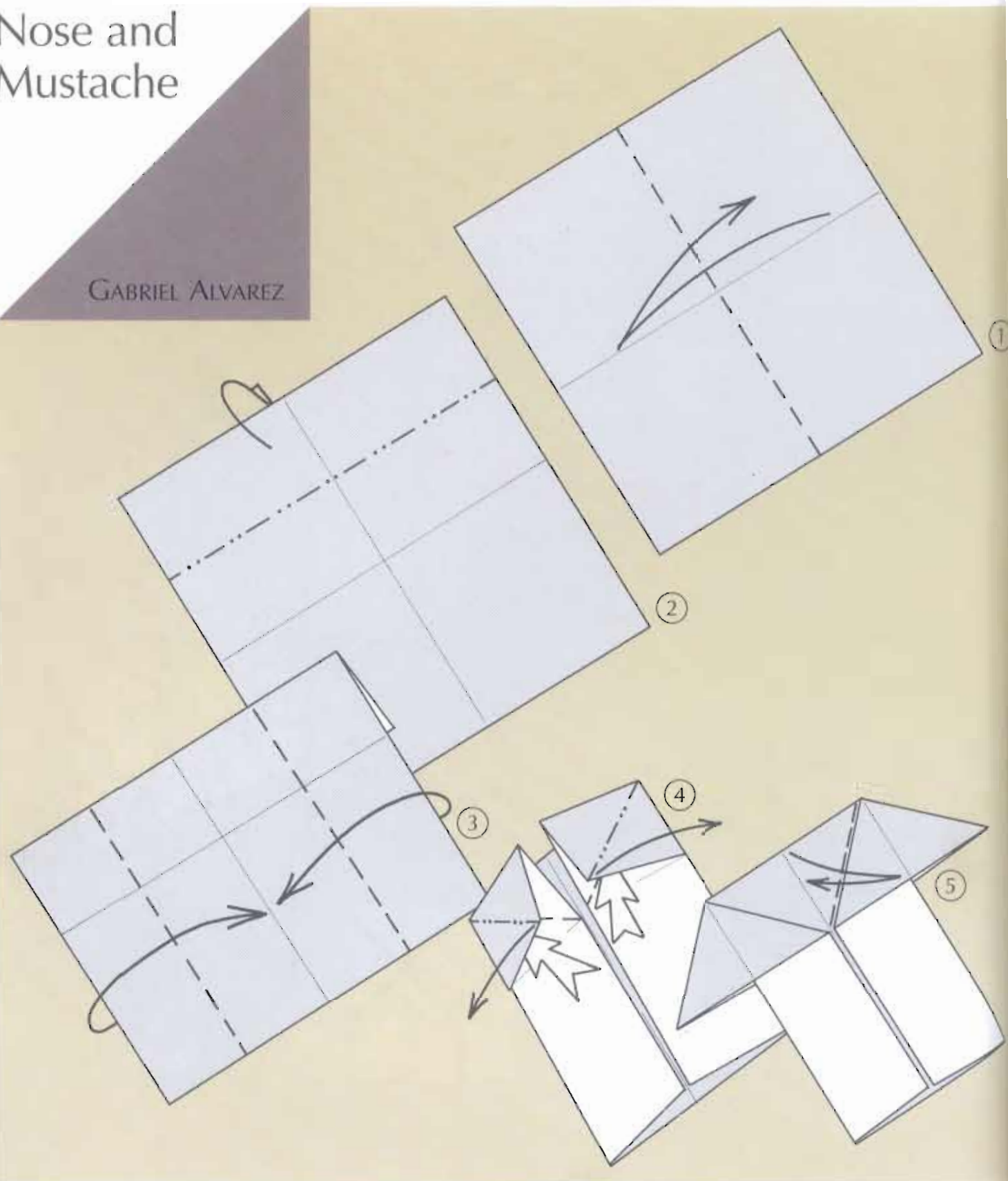

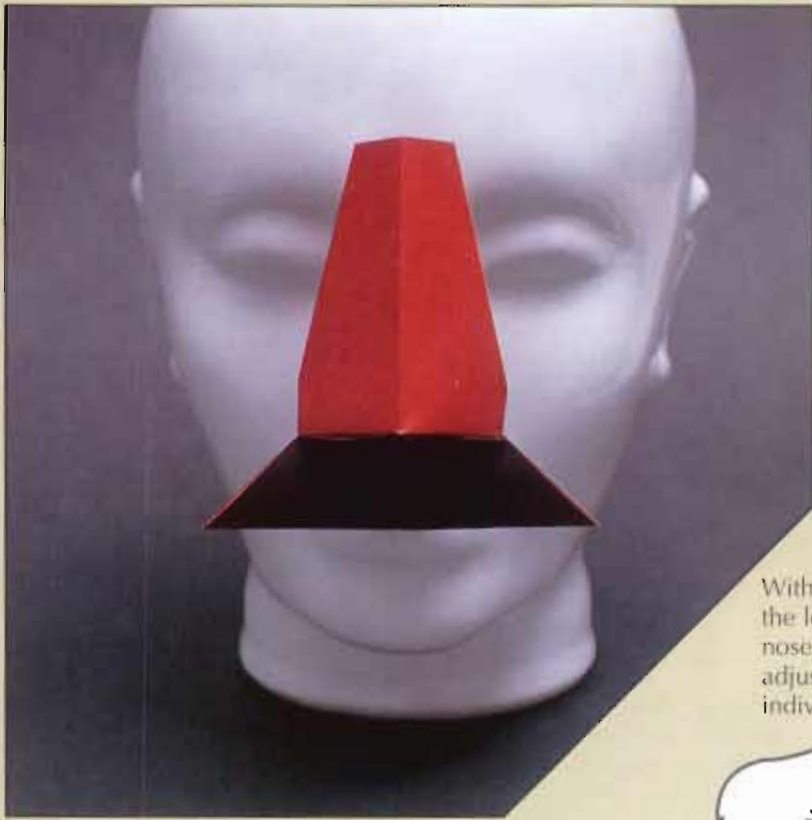

With this fold
the length of the
nose can be
adjusted to fit the
individual.

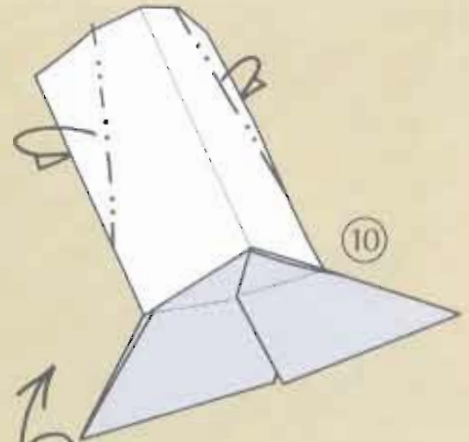
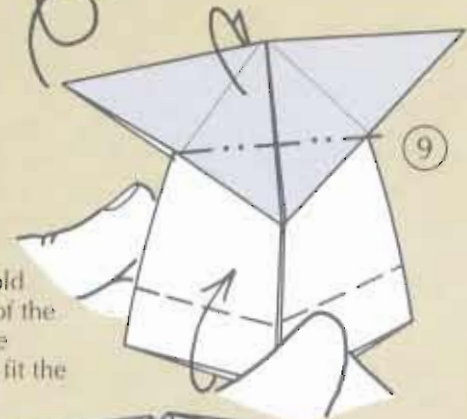
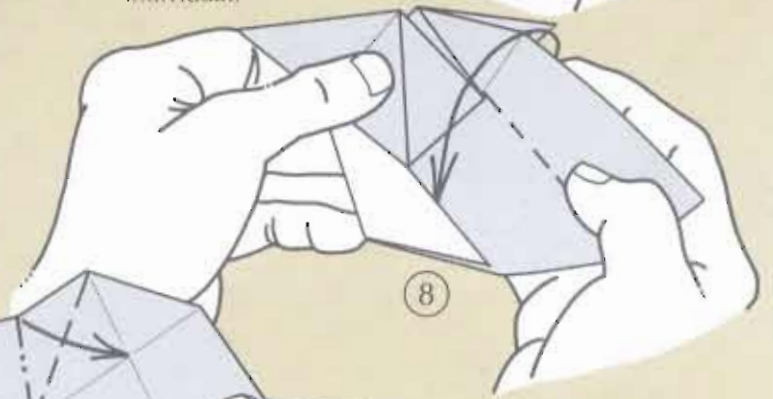
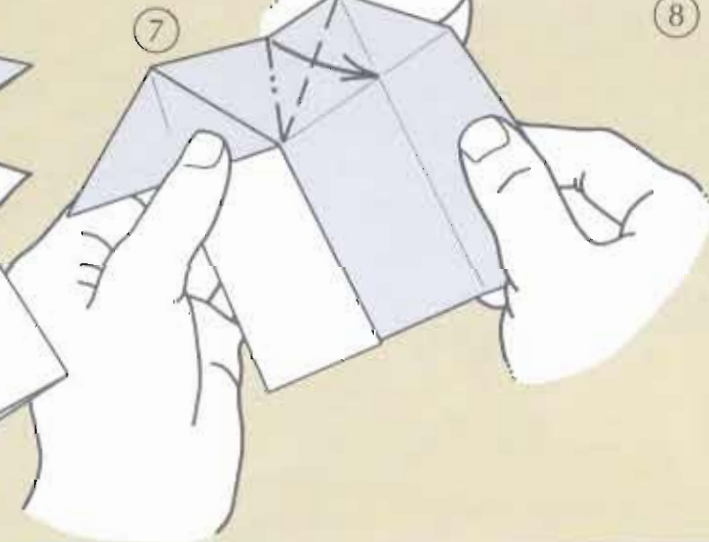
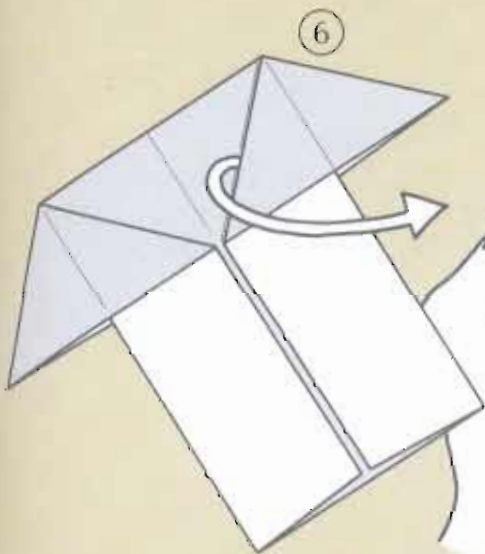

Paperholder

HUMI HUZITA

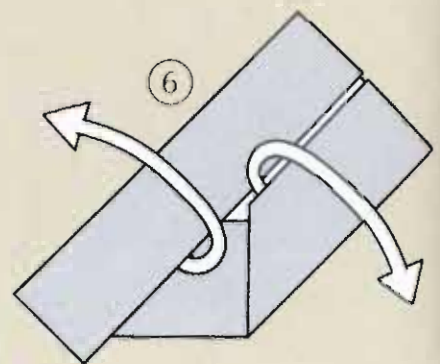
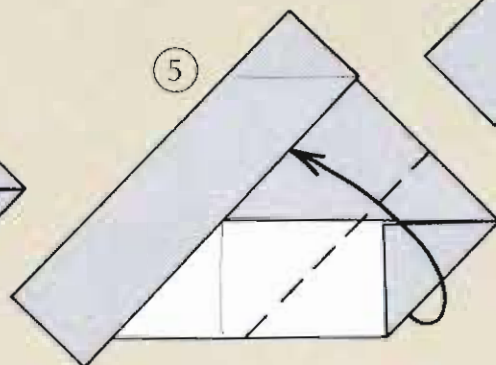
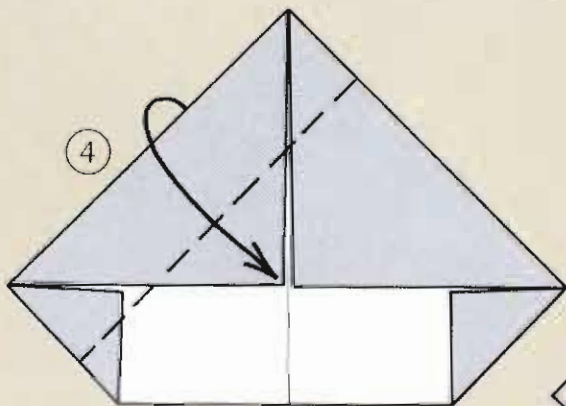
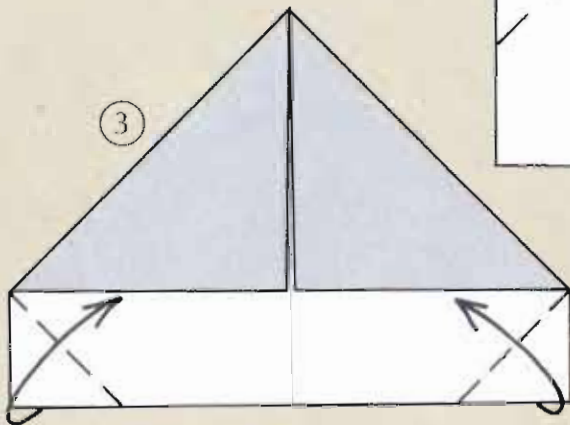
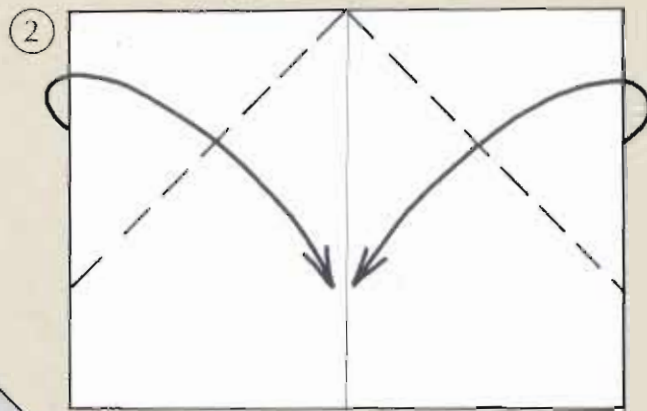
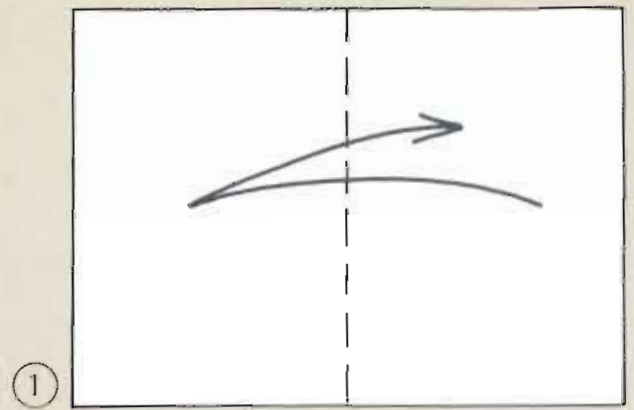

This model by Professor Humi Huzita can be used for many purposes. When paper size 11.6 x 8.25 in (29.7 x 21 cm) is used for this model, depending on the thickness of the paper, it will be suitable for a "caddy" with a base measuring approximately 4 x 4 in (10.5 x 10.5 cm) that can be used for holding memo-paper, and also for computer disks or for music cassettes. For the origami paperholder shown in the picture (base 6 x 6 in (15 x 15 cm)), I have used a starting size of 17 x 12 in (42.5 x 30.2 cm).

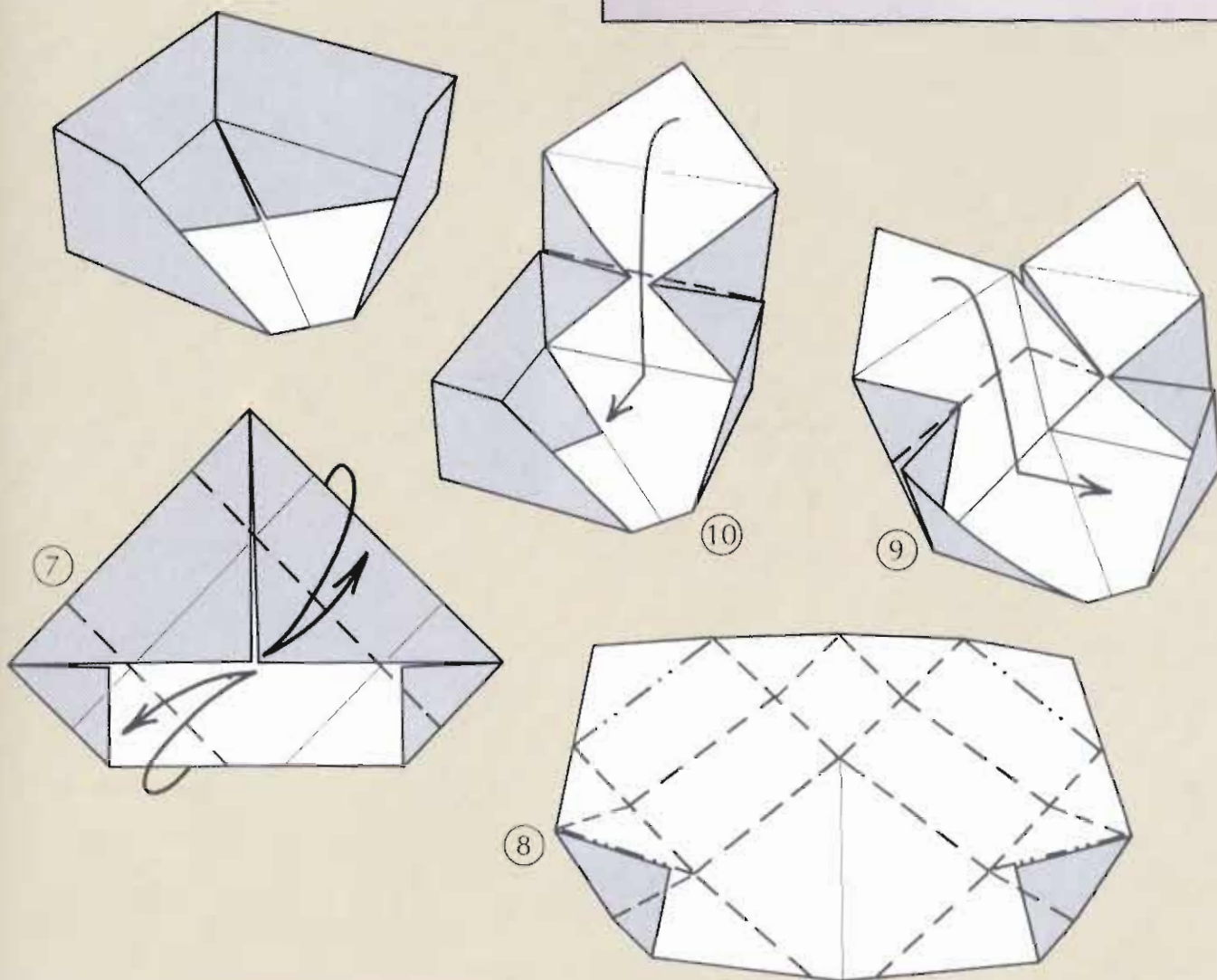
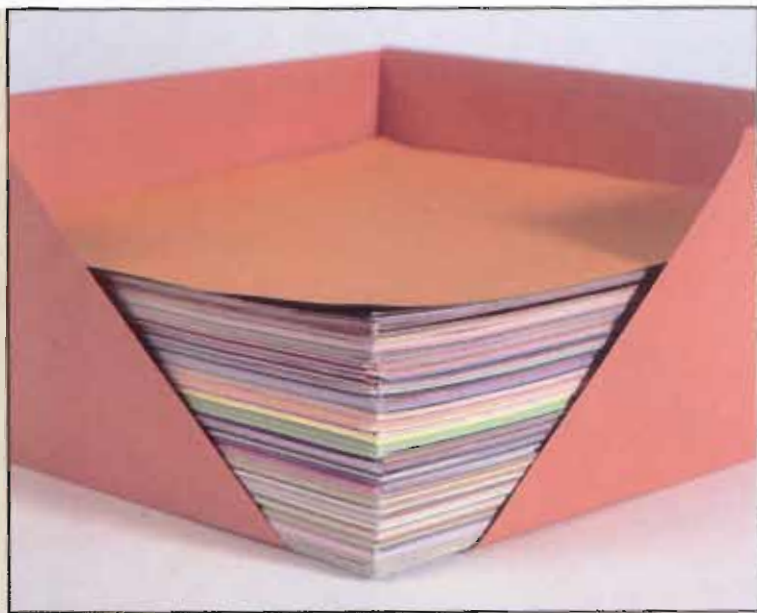

Double Hearts

FRANCIS OW

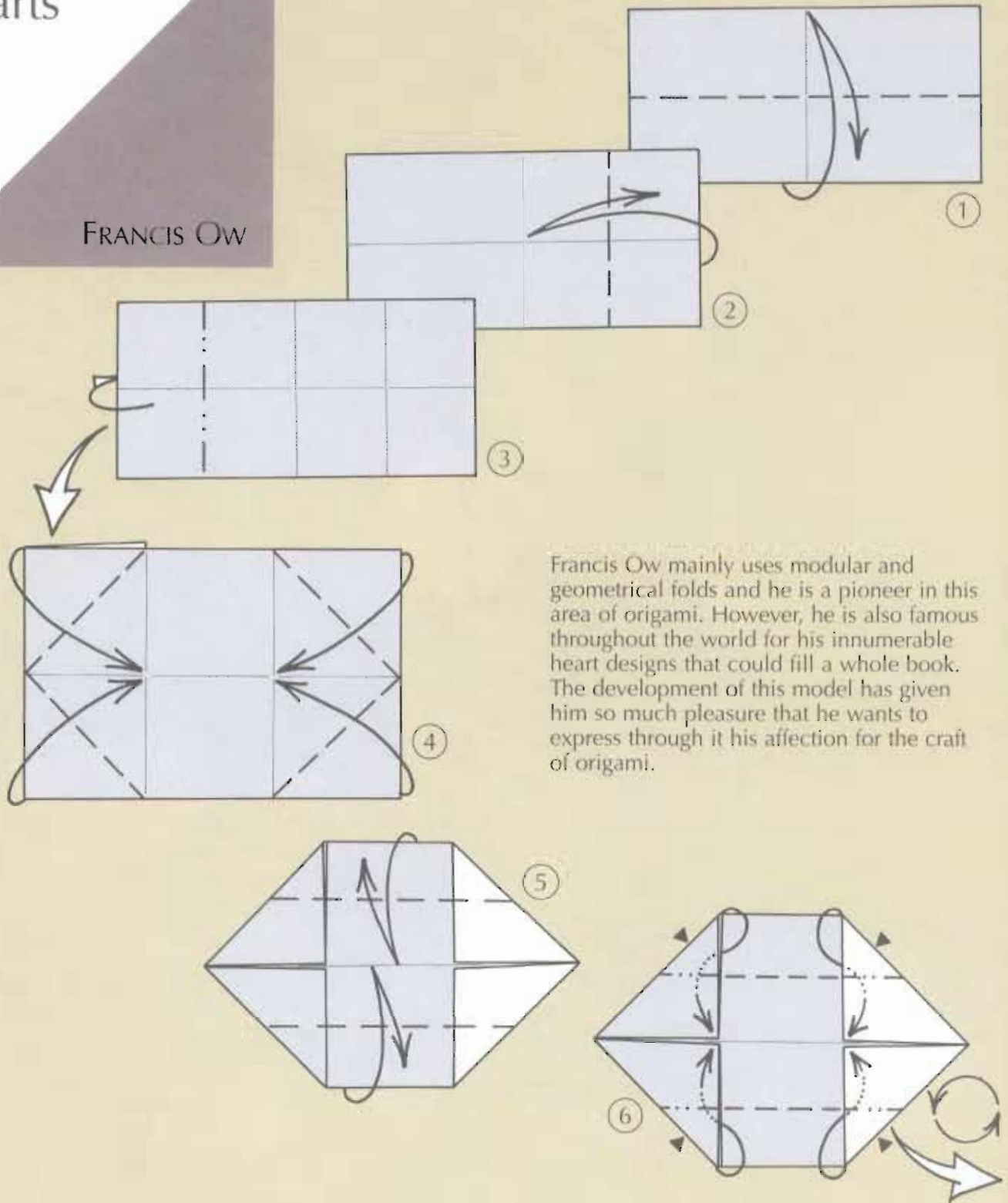

Francis Ow mainly uses modular and geometrical folds and he is a pioneer in this area of origami. However, he is also famous throughout the world for his innumerable heart designs that could fill a whole book. The development of this model has given him so much pleasure that he wants to express through it his affection for the craft of origami.

Fold only the front layer of the paper again.

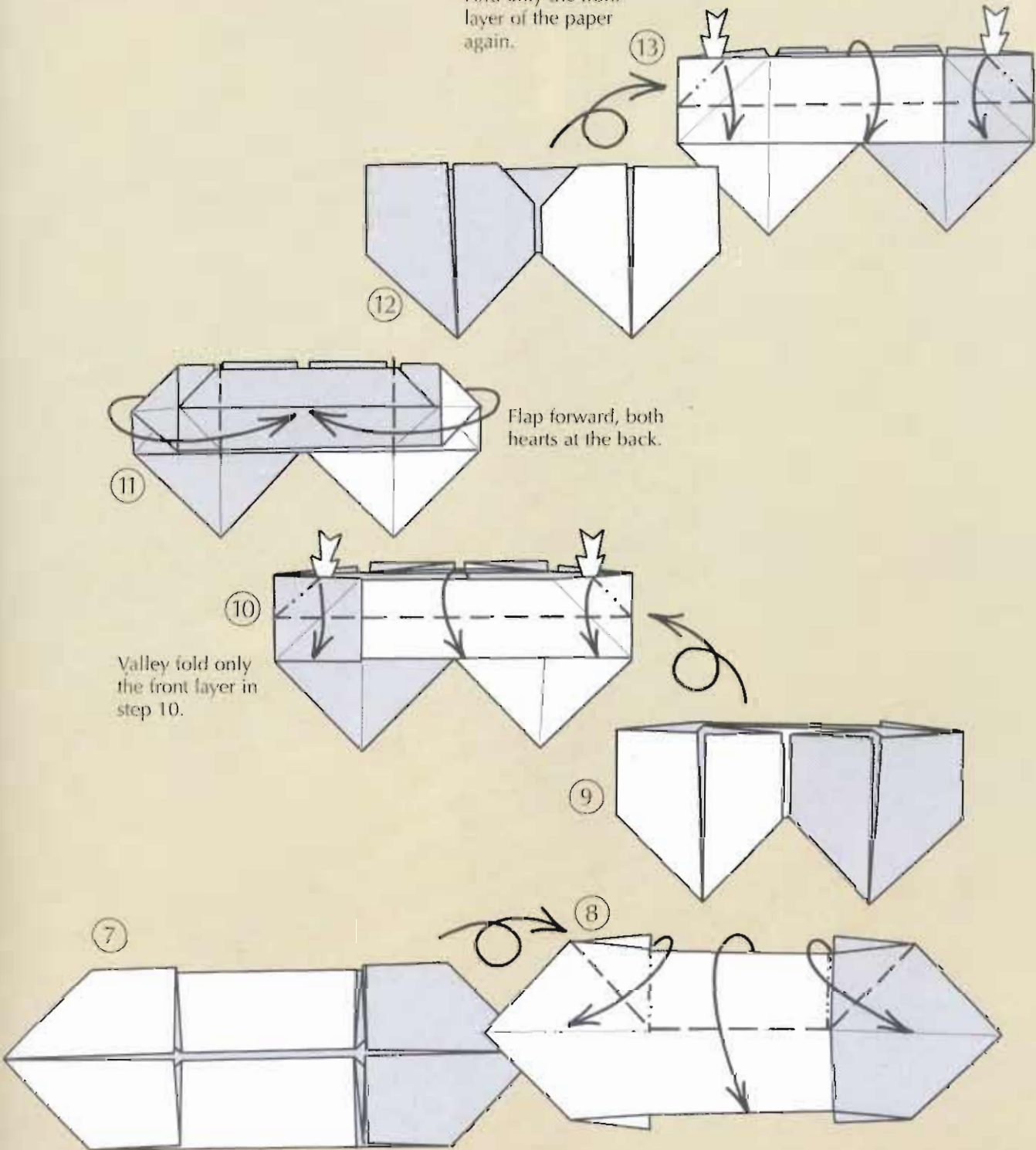

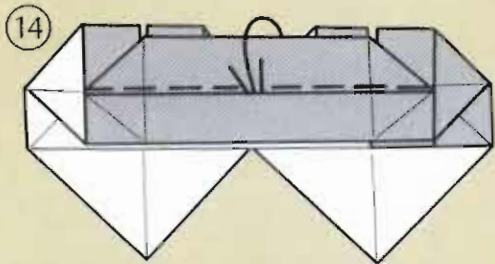

Hide the bridge on the inside.

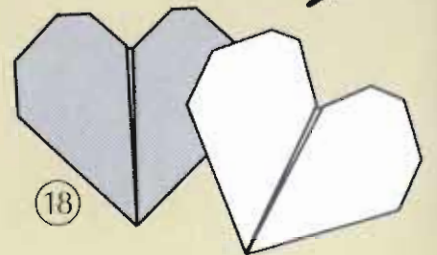
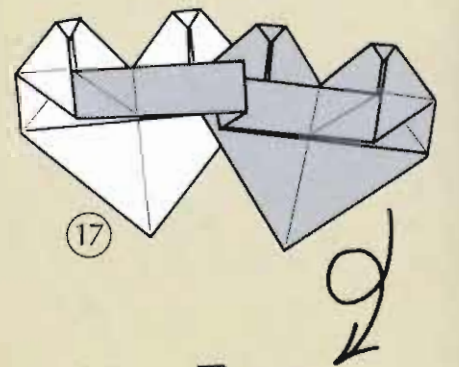
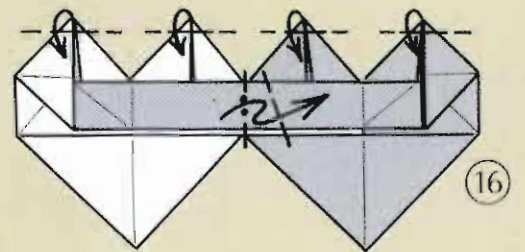
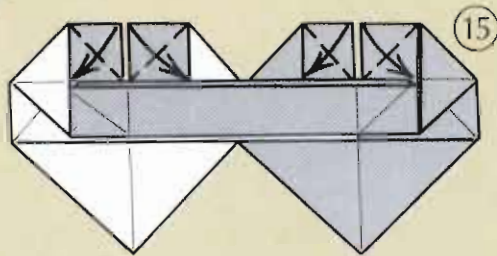

Cup

PAULO MULATINHO

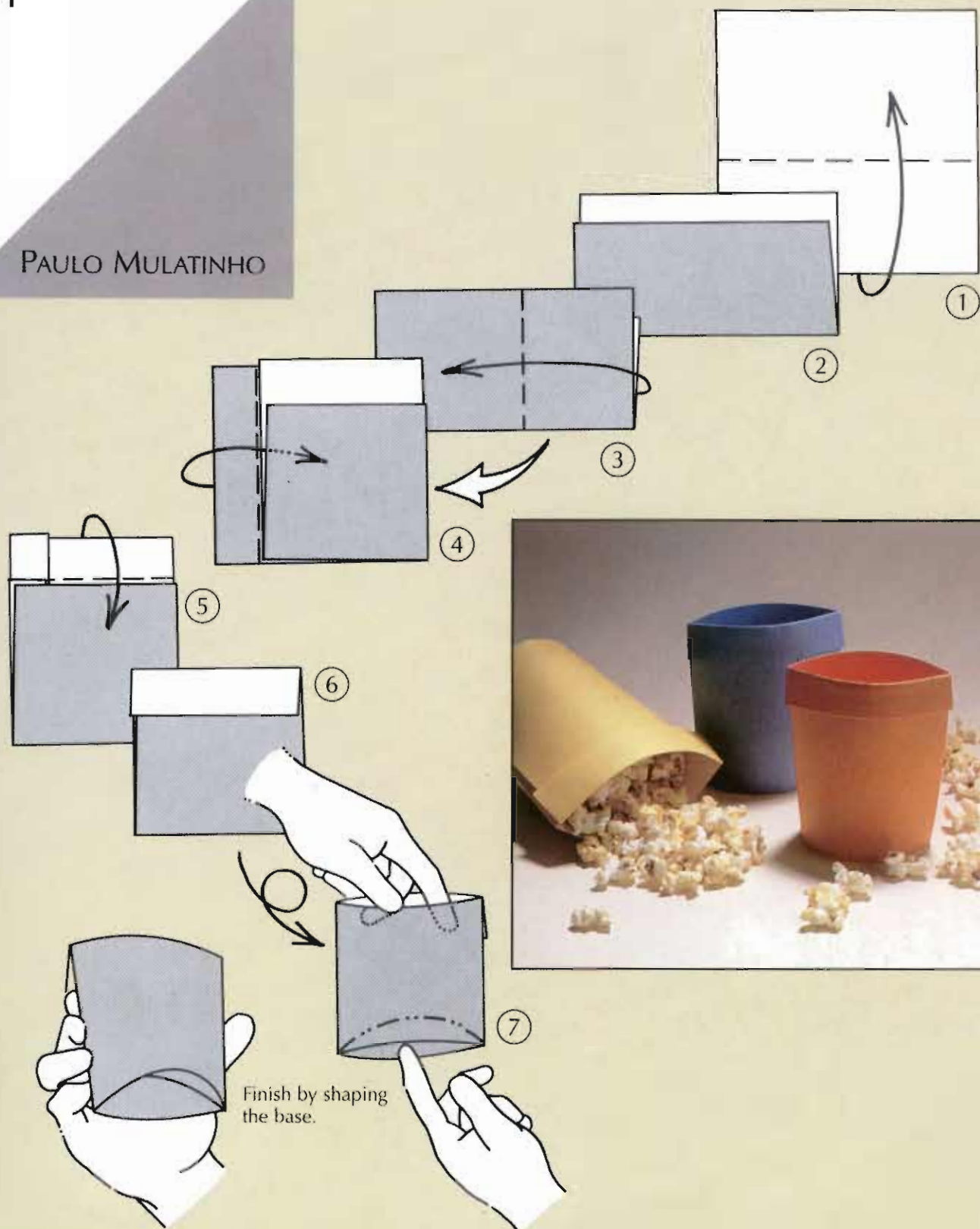

The Shirt Off One's Back

TRADITIONAL

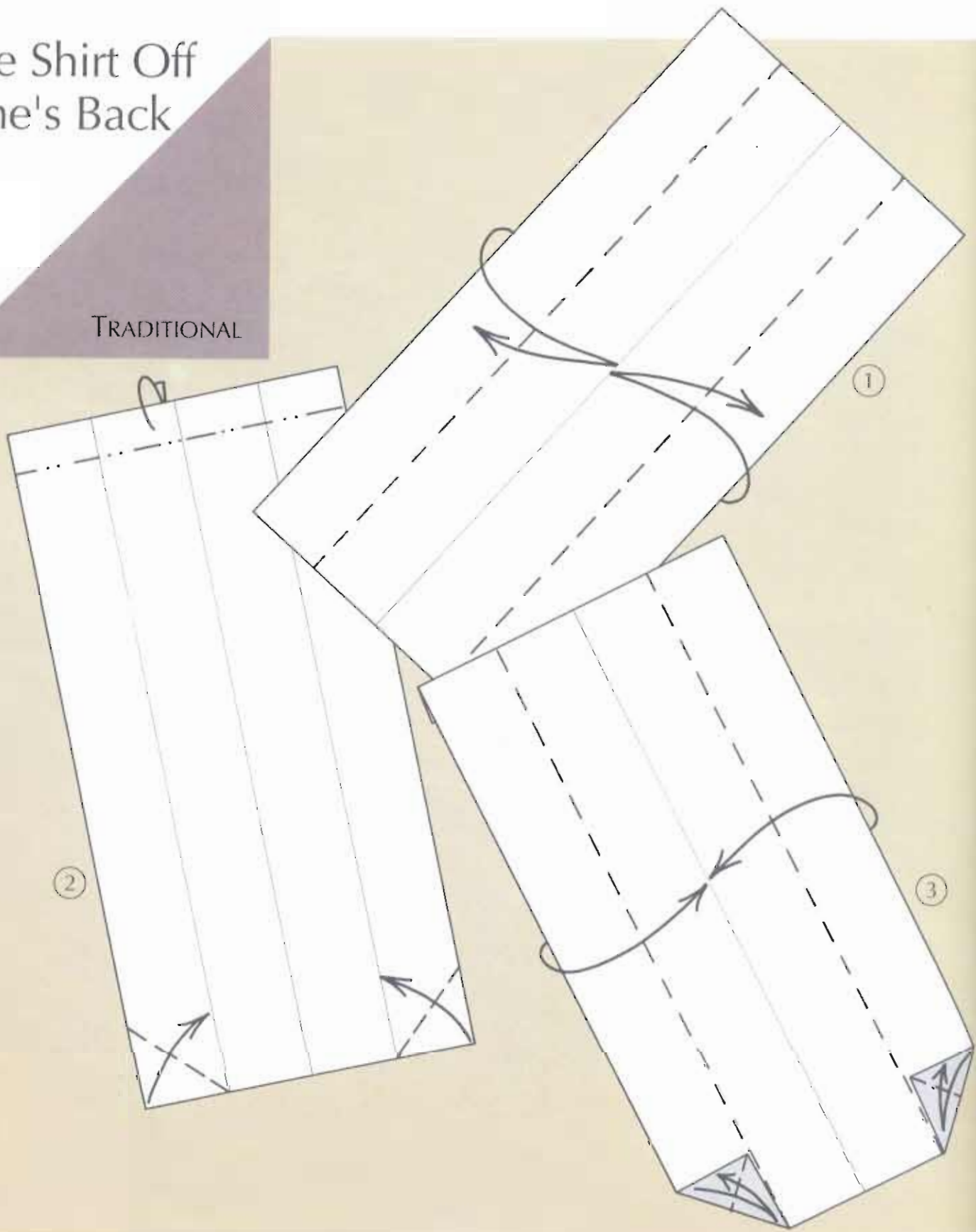

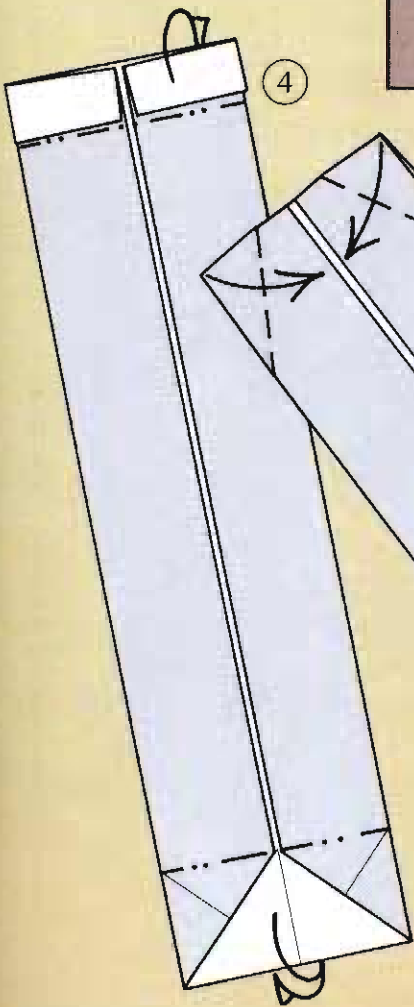

4

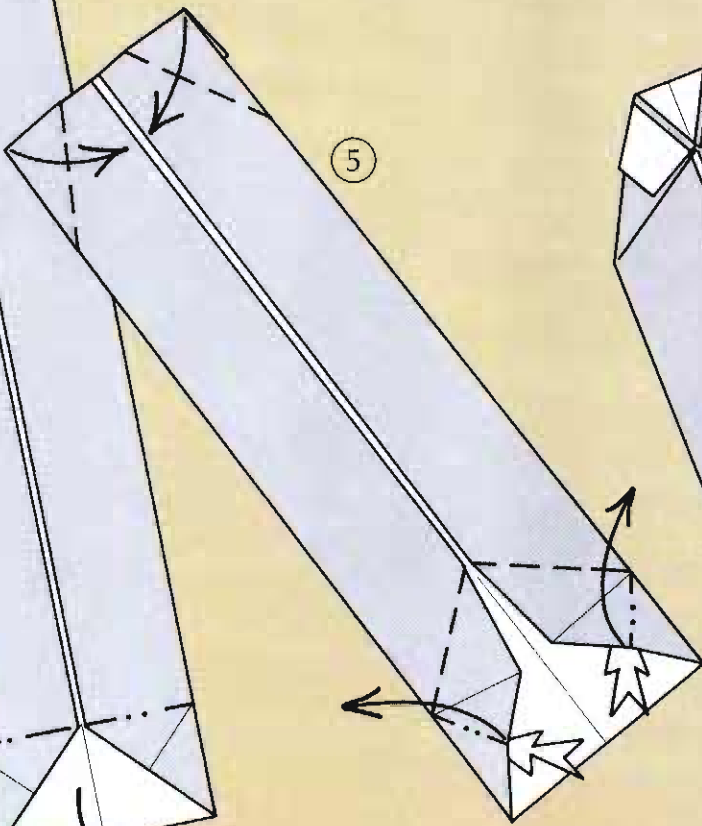

5

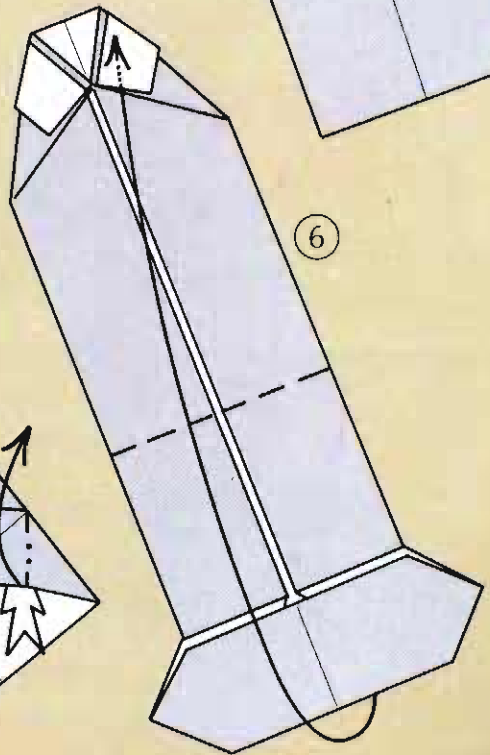

6

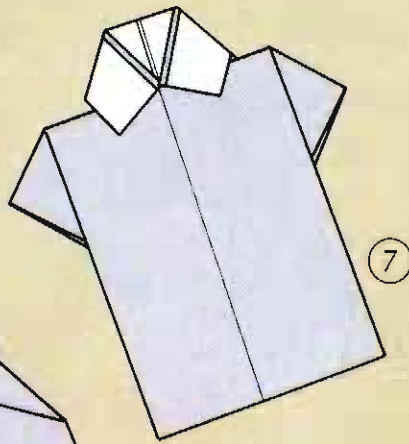

7

Arrow

PAULO MULATINHO

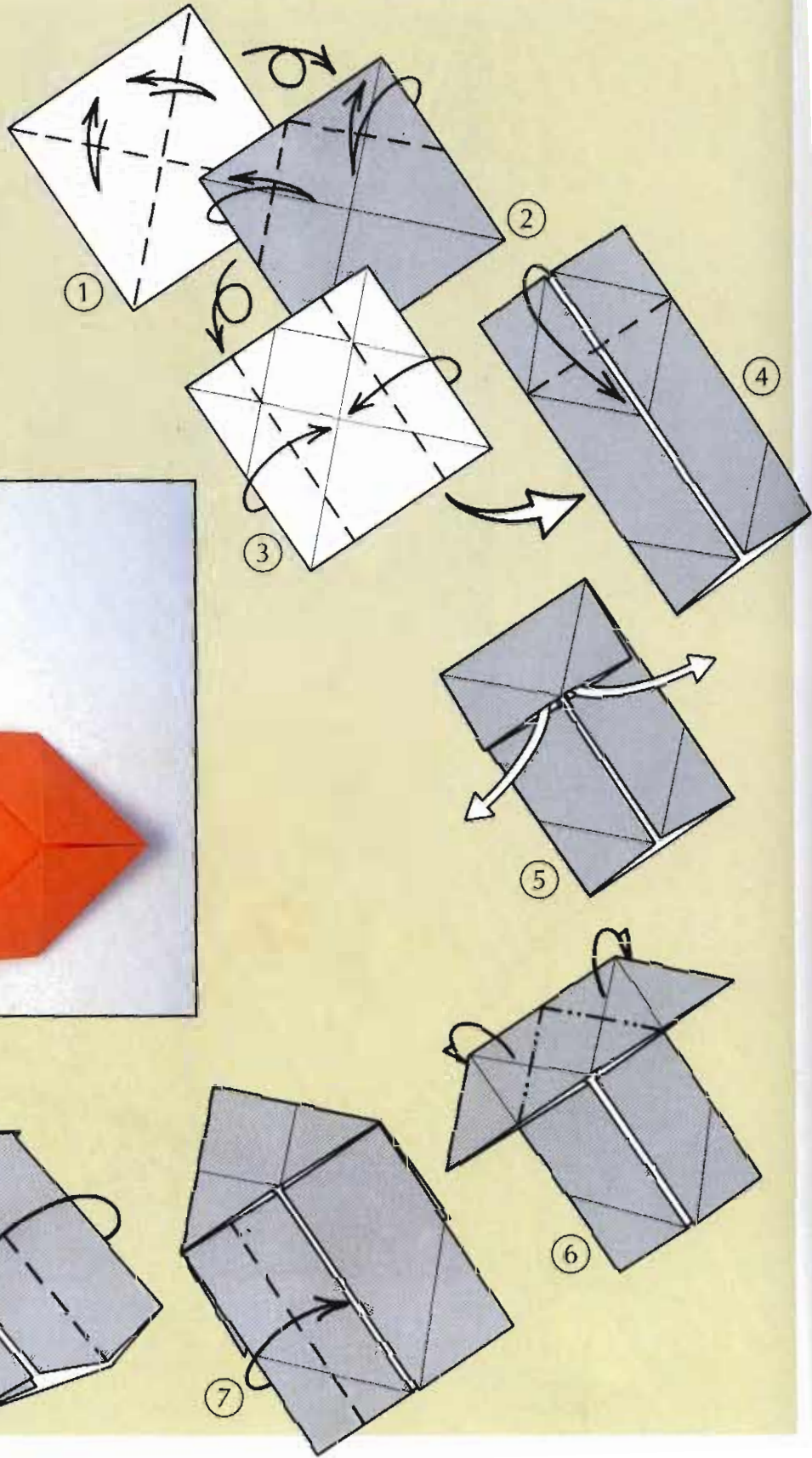
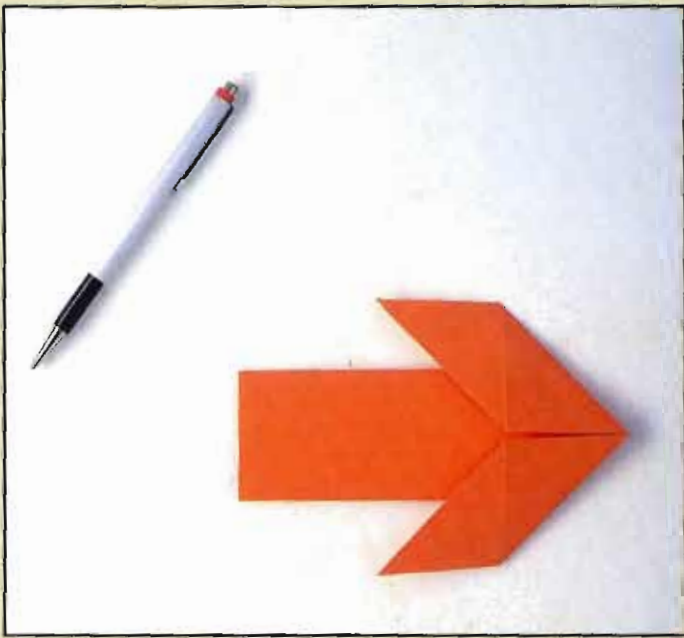

Object

THOKI YENN

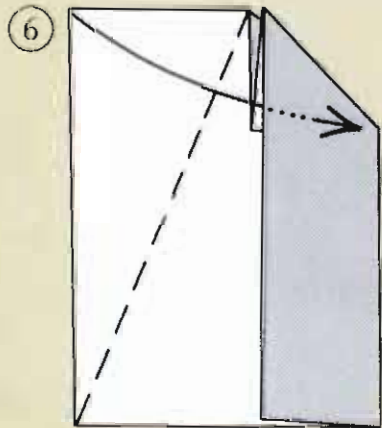
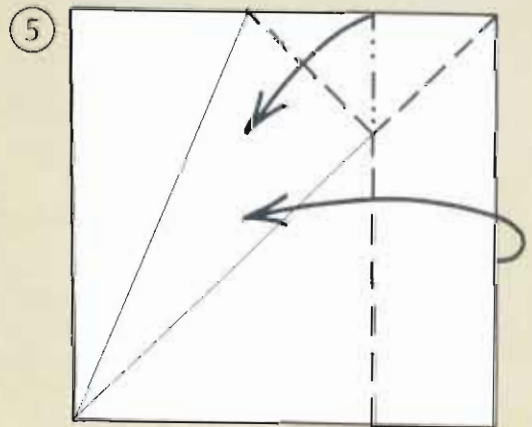
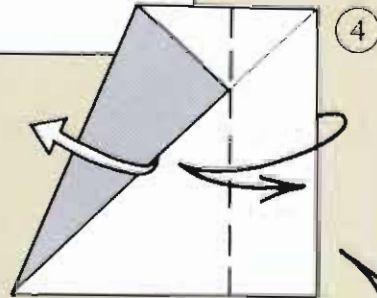
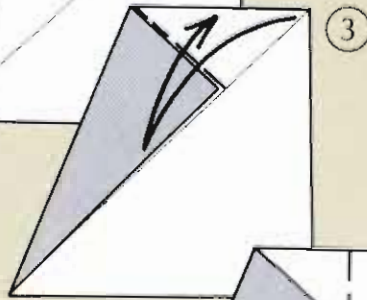
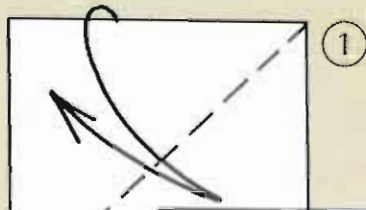
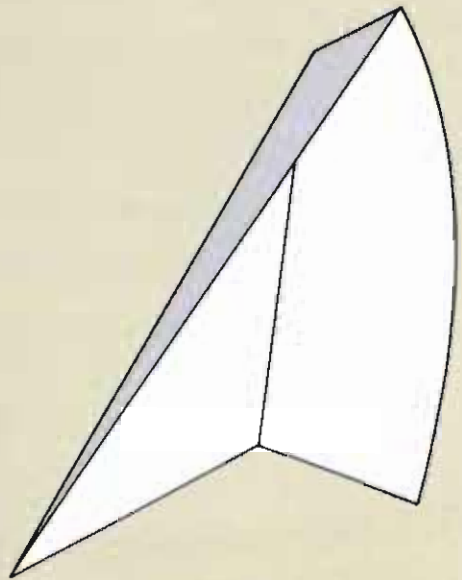

Nun

KUNIHICO KASAHARA

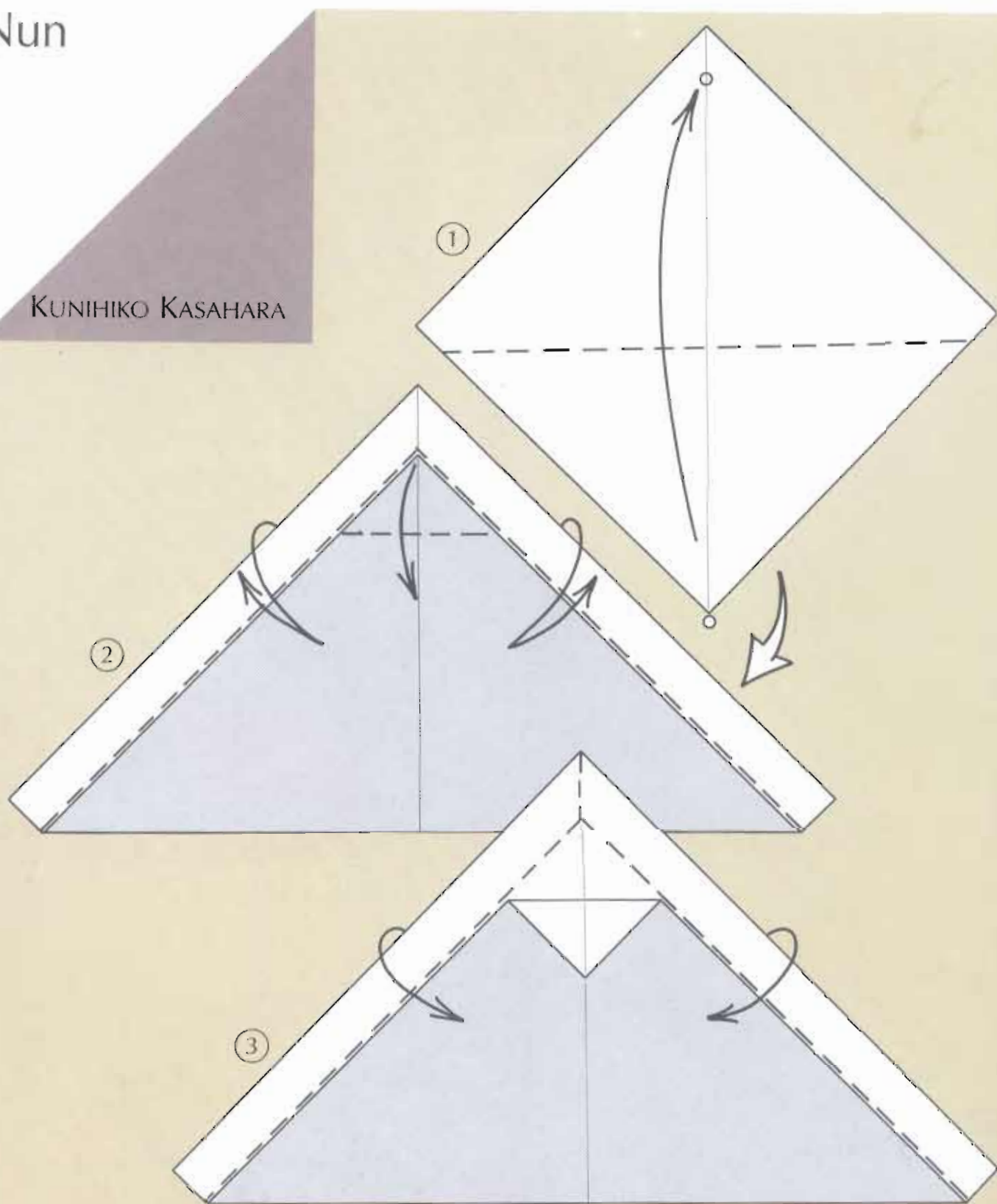

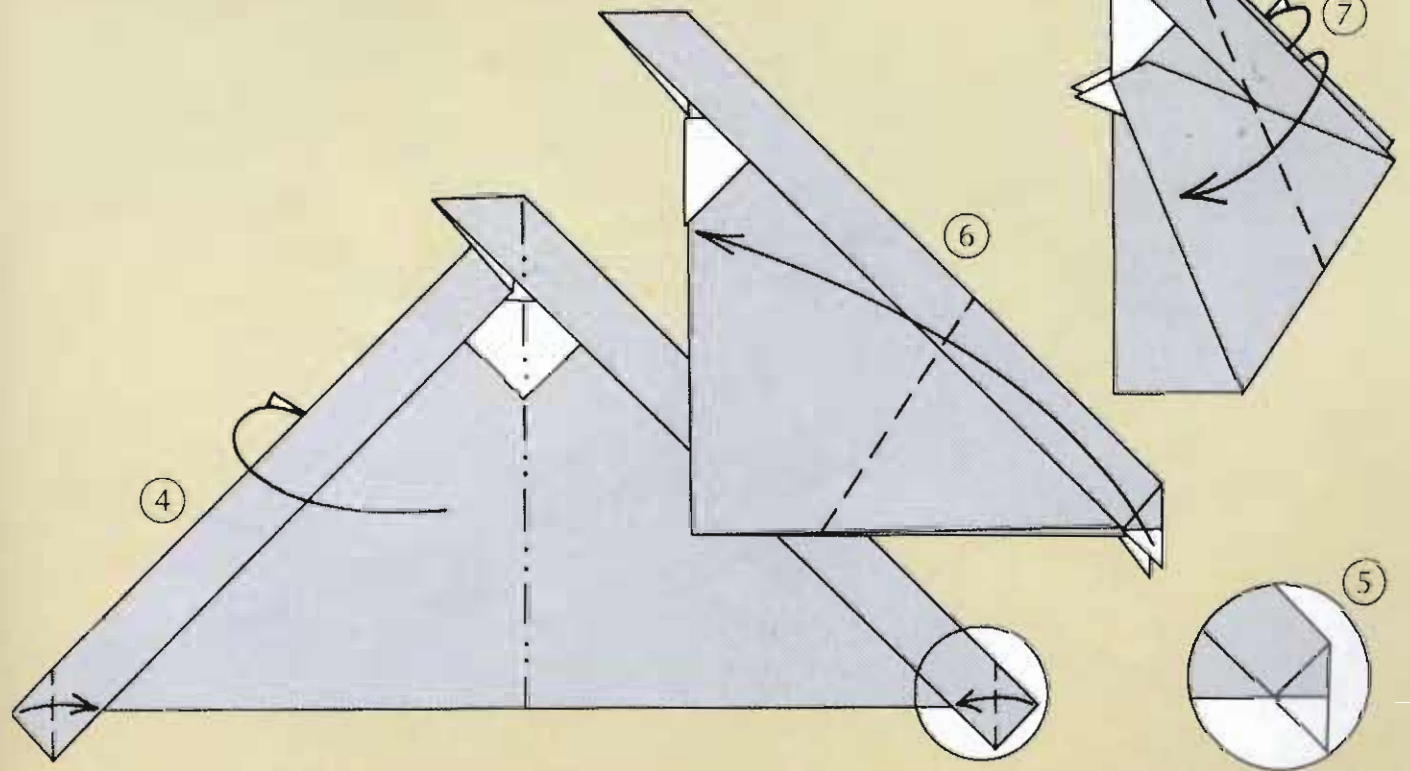

Pipe

EDWARD MEGRATH

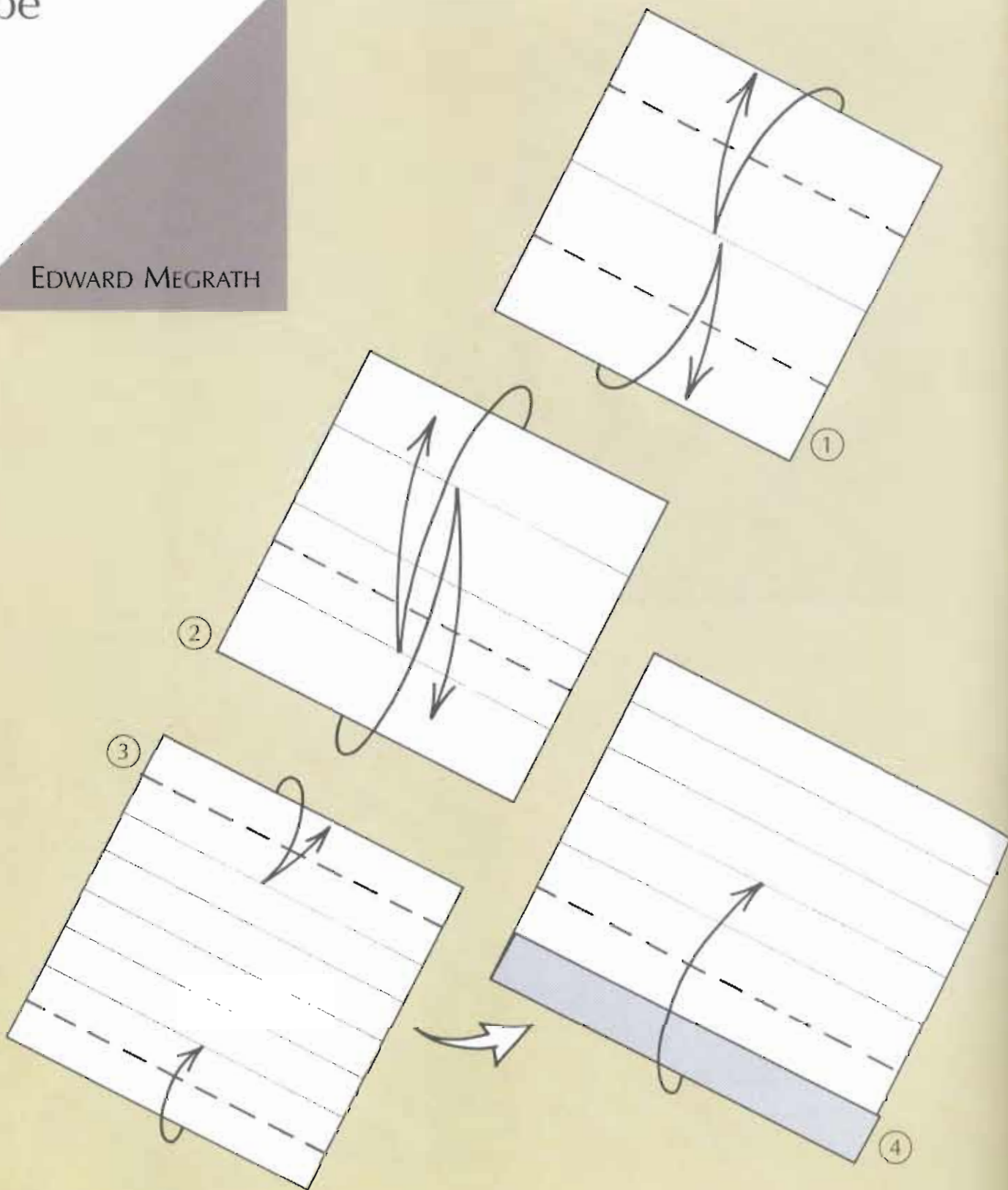

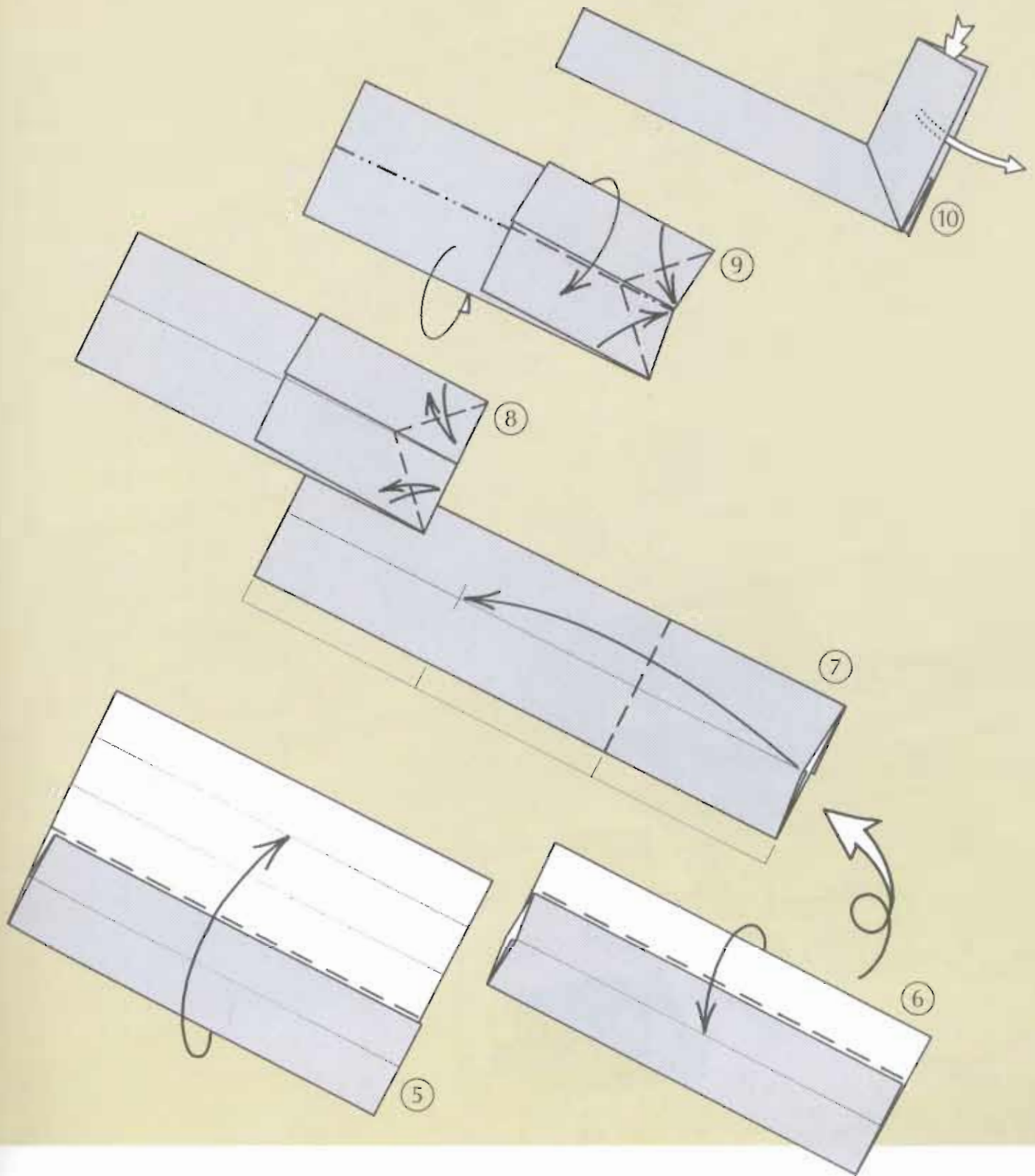

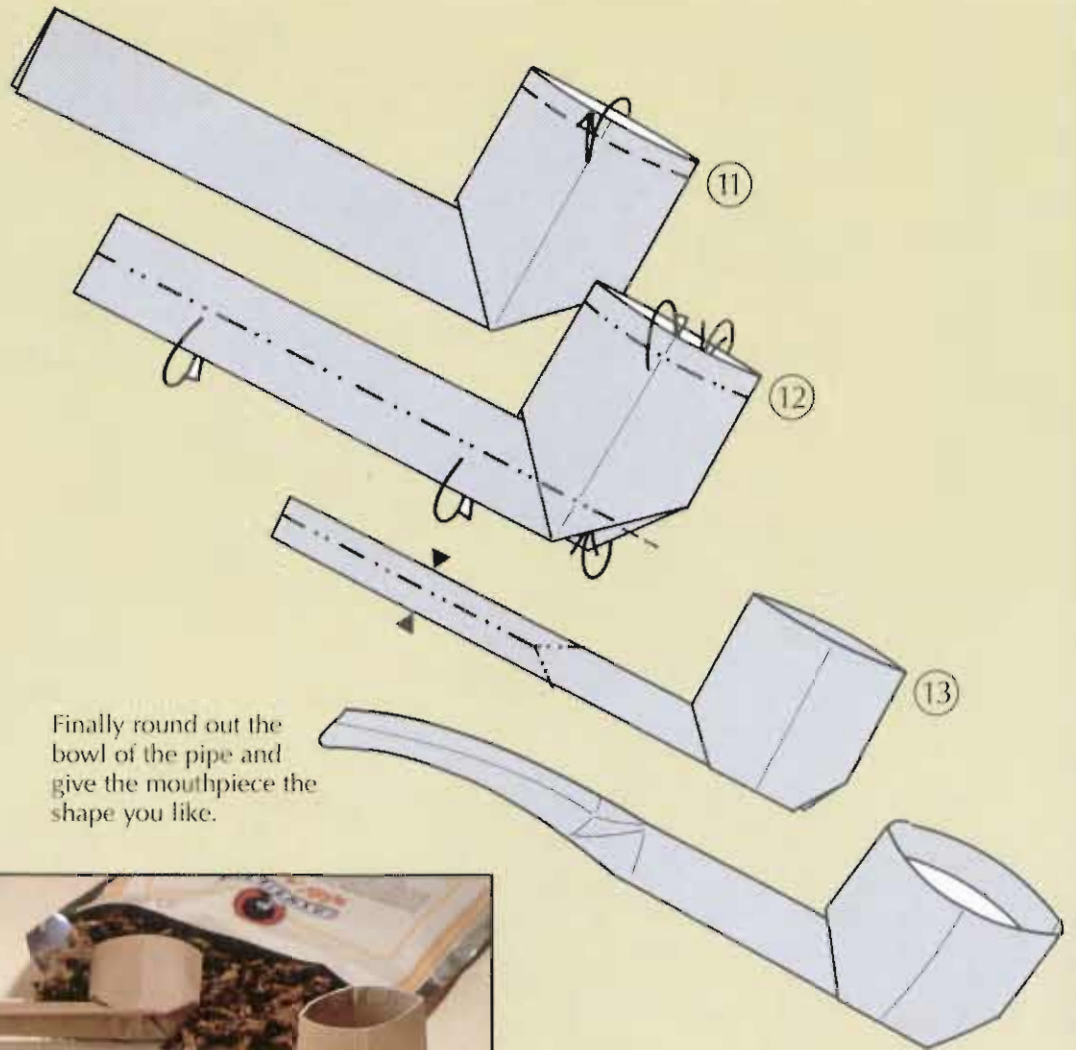

Finally round out the bowl of the pipe and give the mouthpiece the shape you like.



Origami Zoo



Shy Young Hare

THOKI YENN

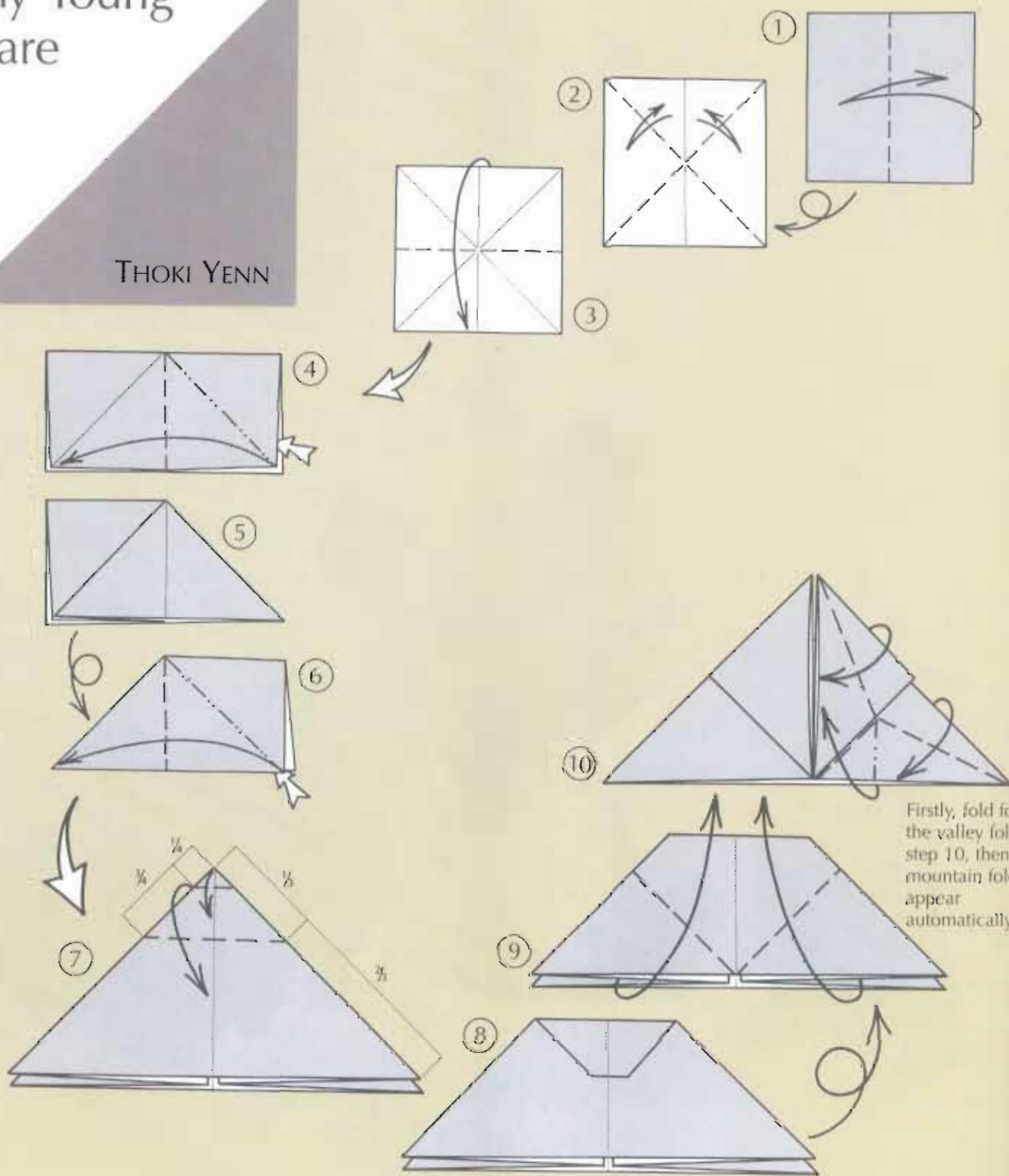

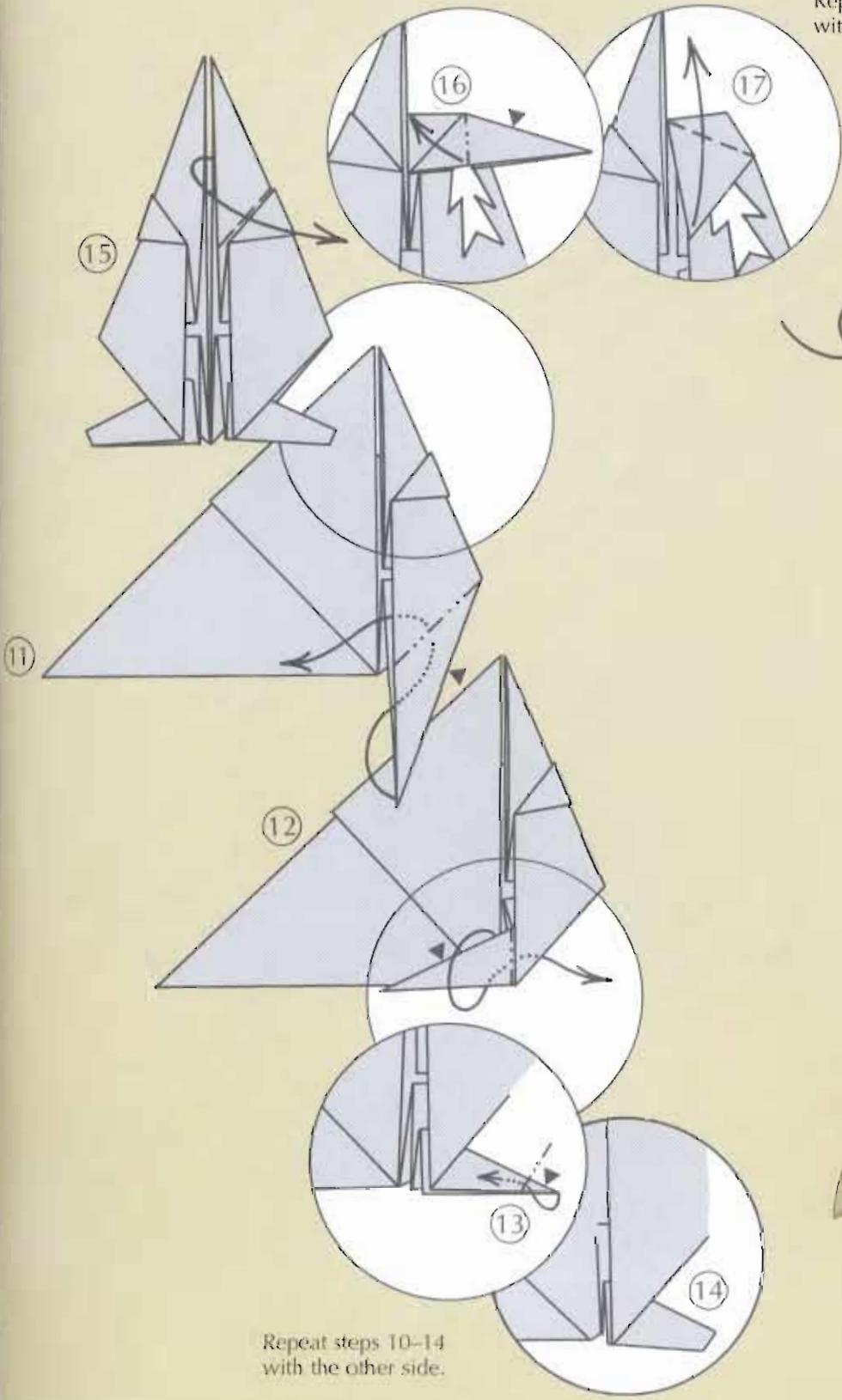

Repeat steps 15-17 with the other side.

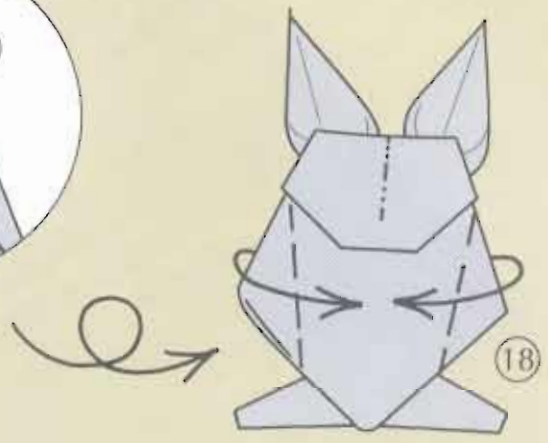

Repeat steps 10-14 with the other side.

ward
in
e
will

Elephant

EDWIN CORRIE

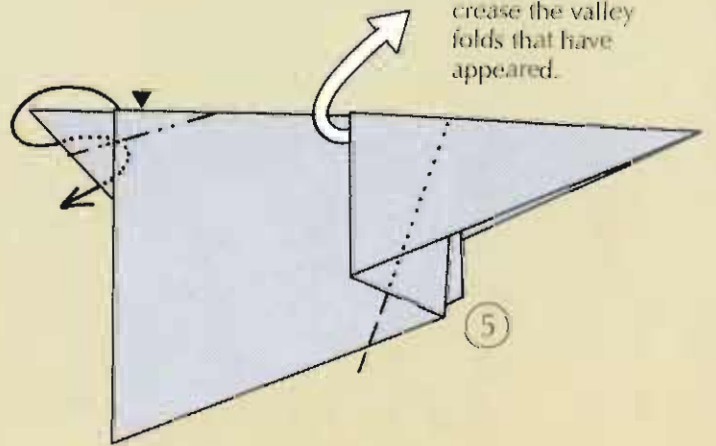
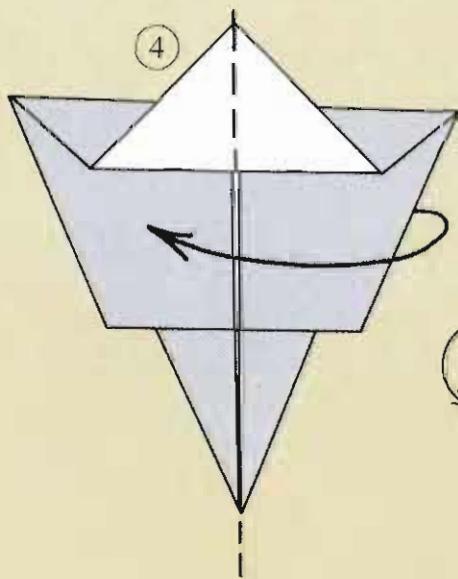
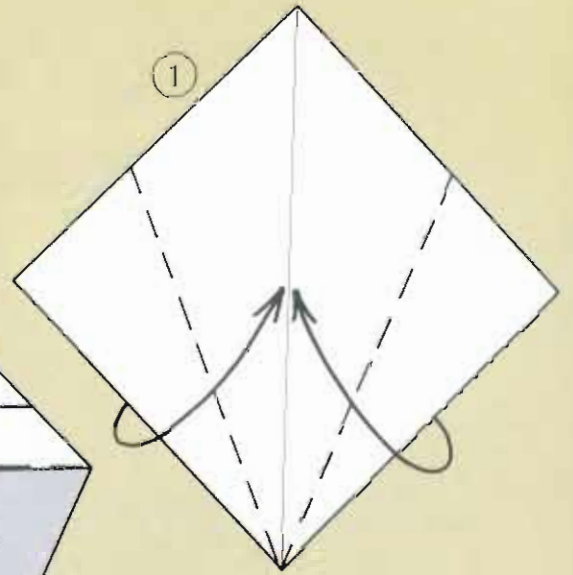
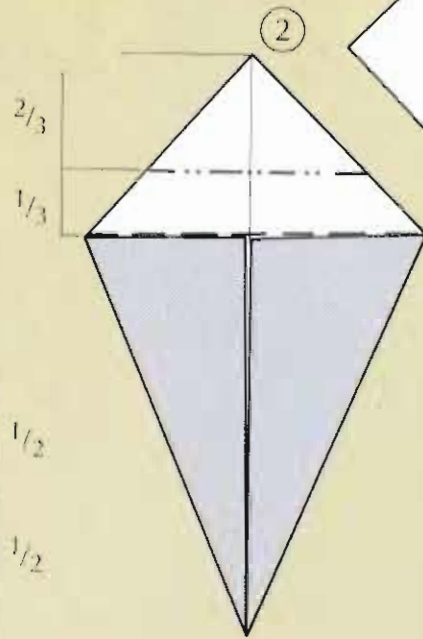
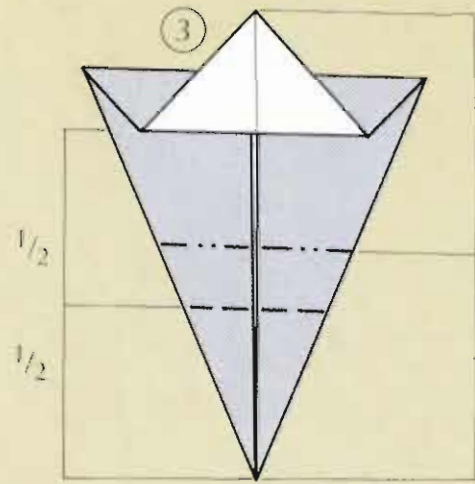

Lift the head at the marked area and bring it into position (see step 6) and crease the valley folds that have appeared.

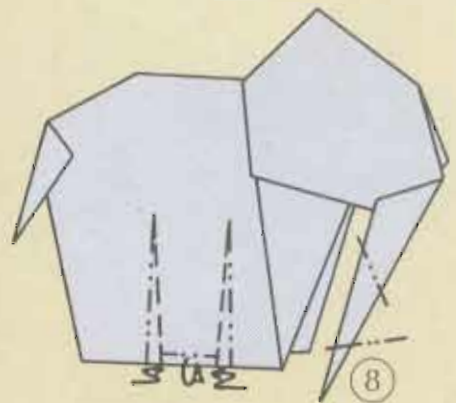

Repeat the folds for the tail and the legs on the back.

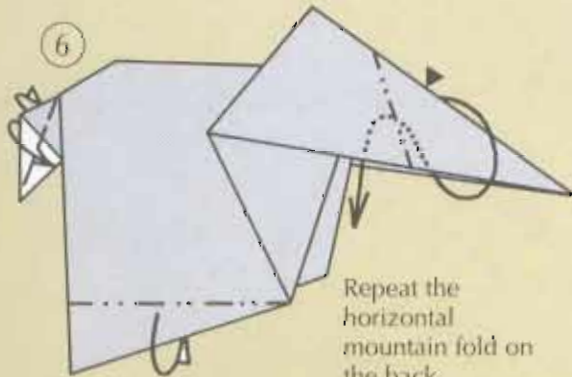

Repeat the horizontal mountain fold on the back.

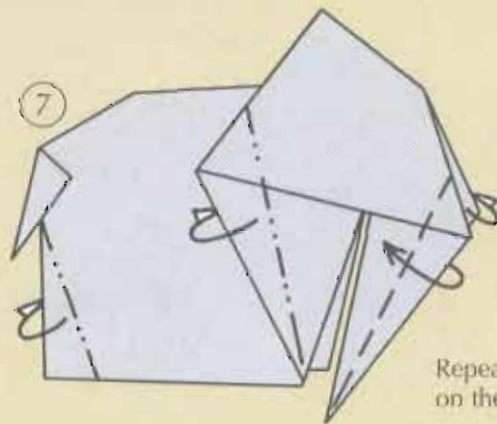

Repeat all the folds on the back.

Frog

JUAN GIMENO

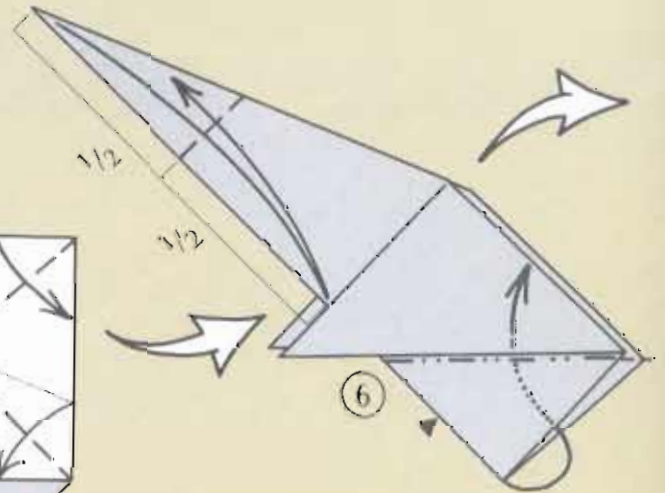
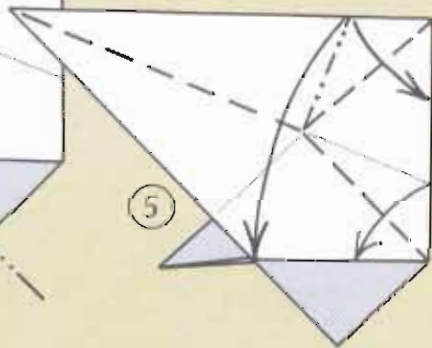
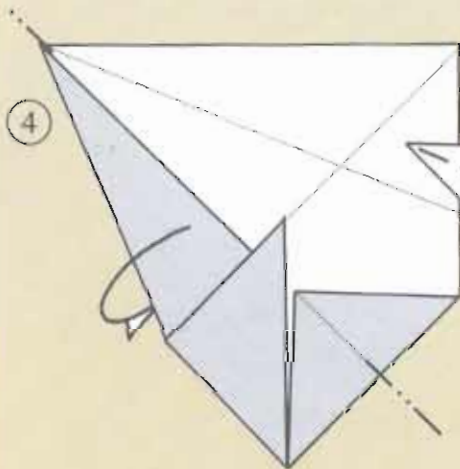
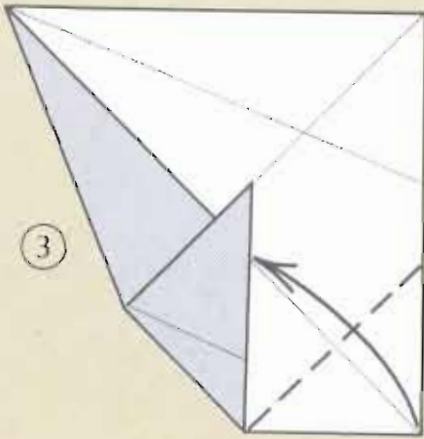
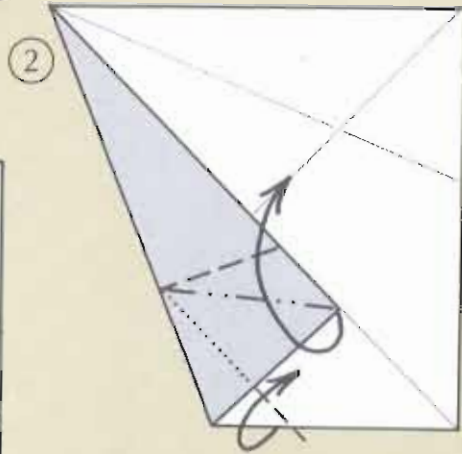
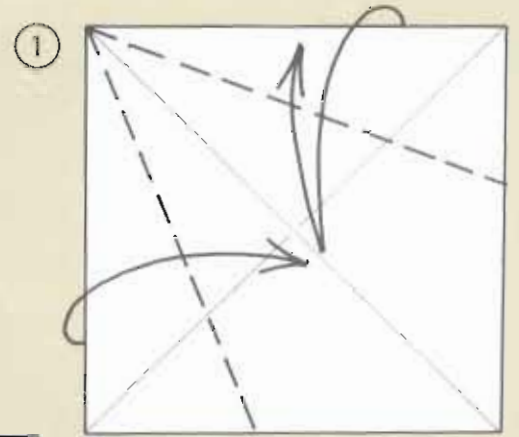

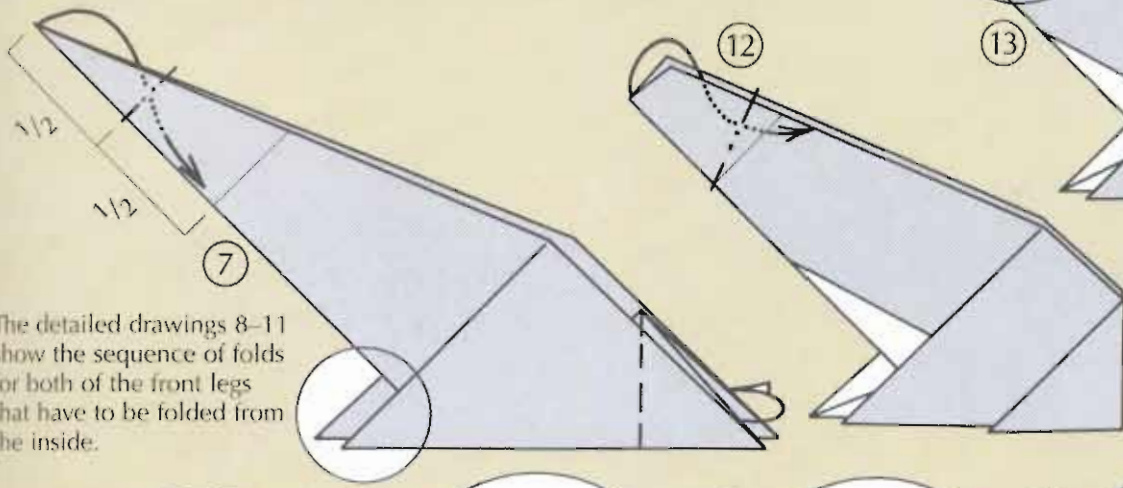
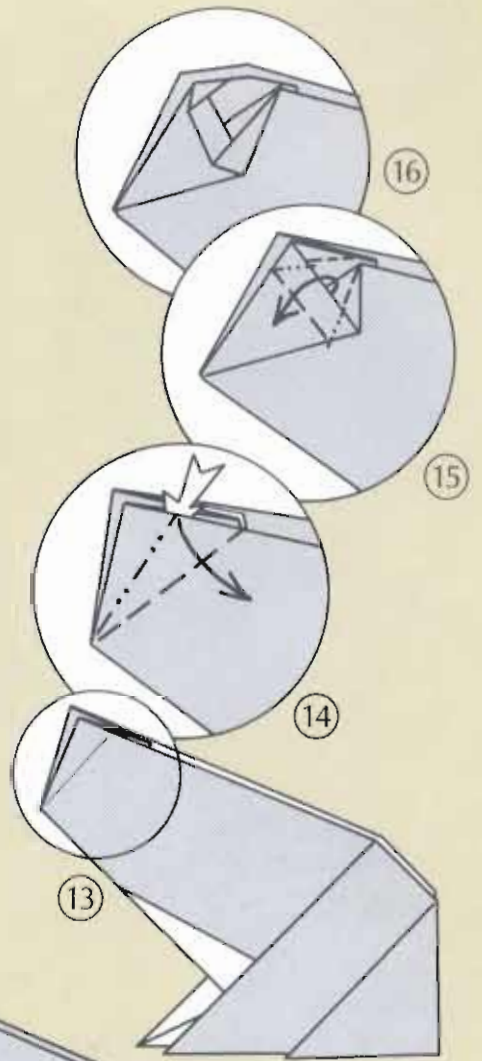
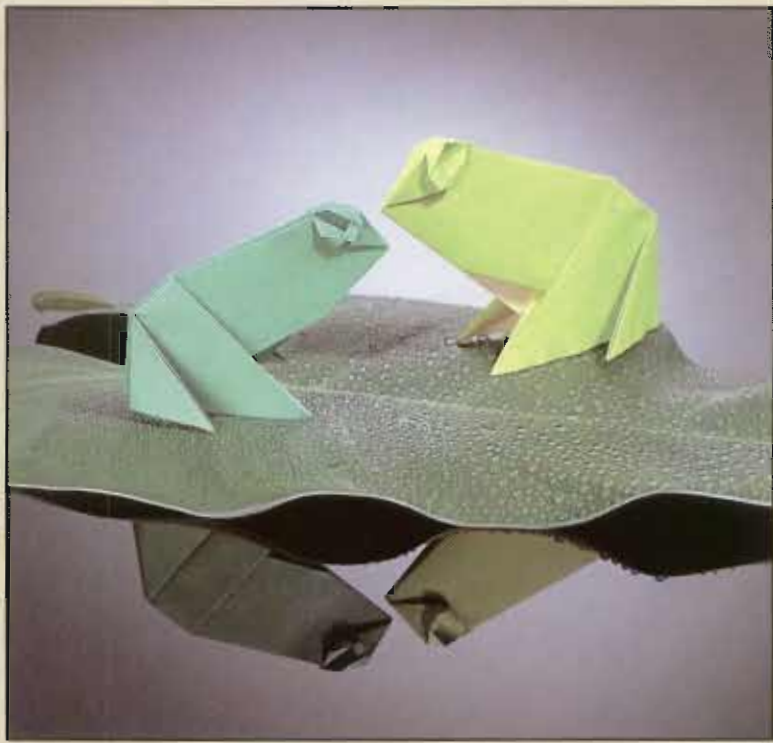

The detailed drawings 8–11 show the sequence of folds for both of the front legs that have to be folded from the inside.

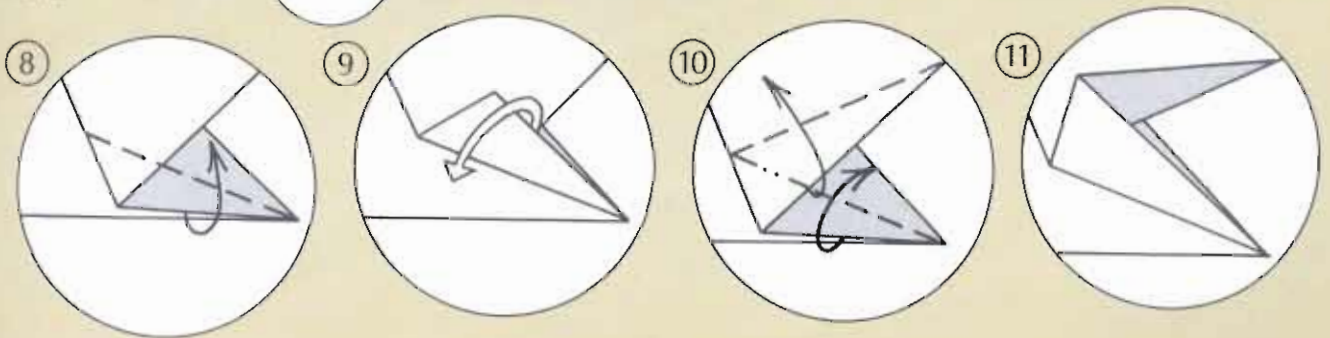

Mouse

EDUARDO CLEMENTE

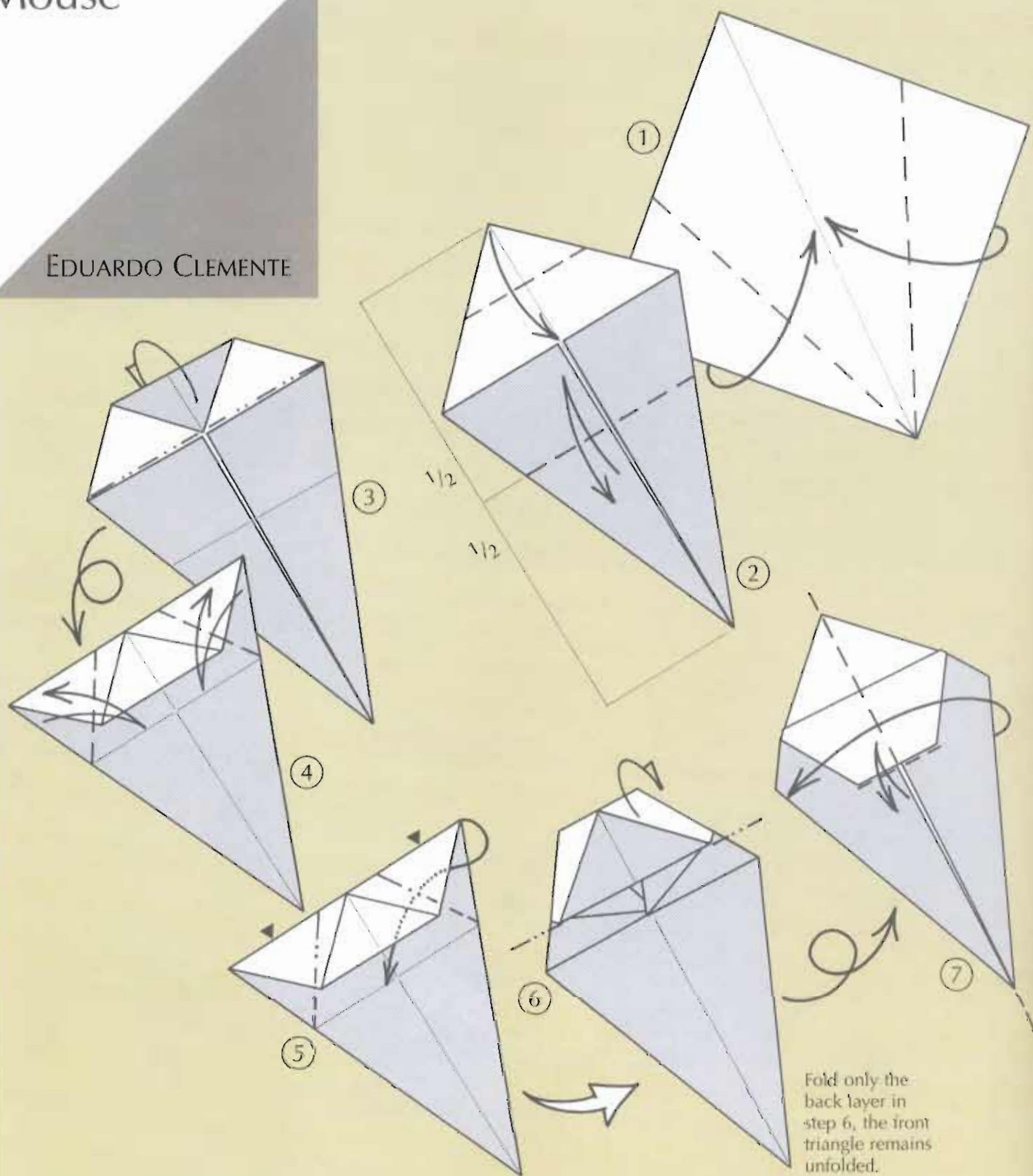

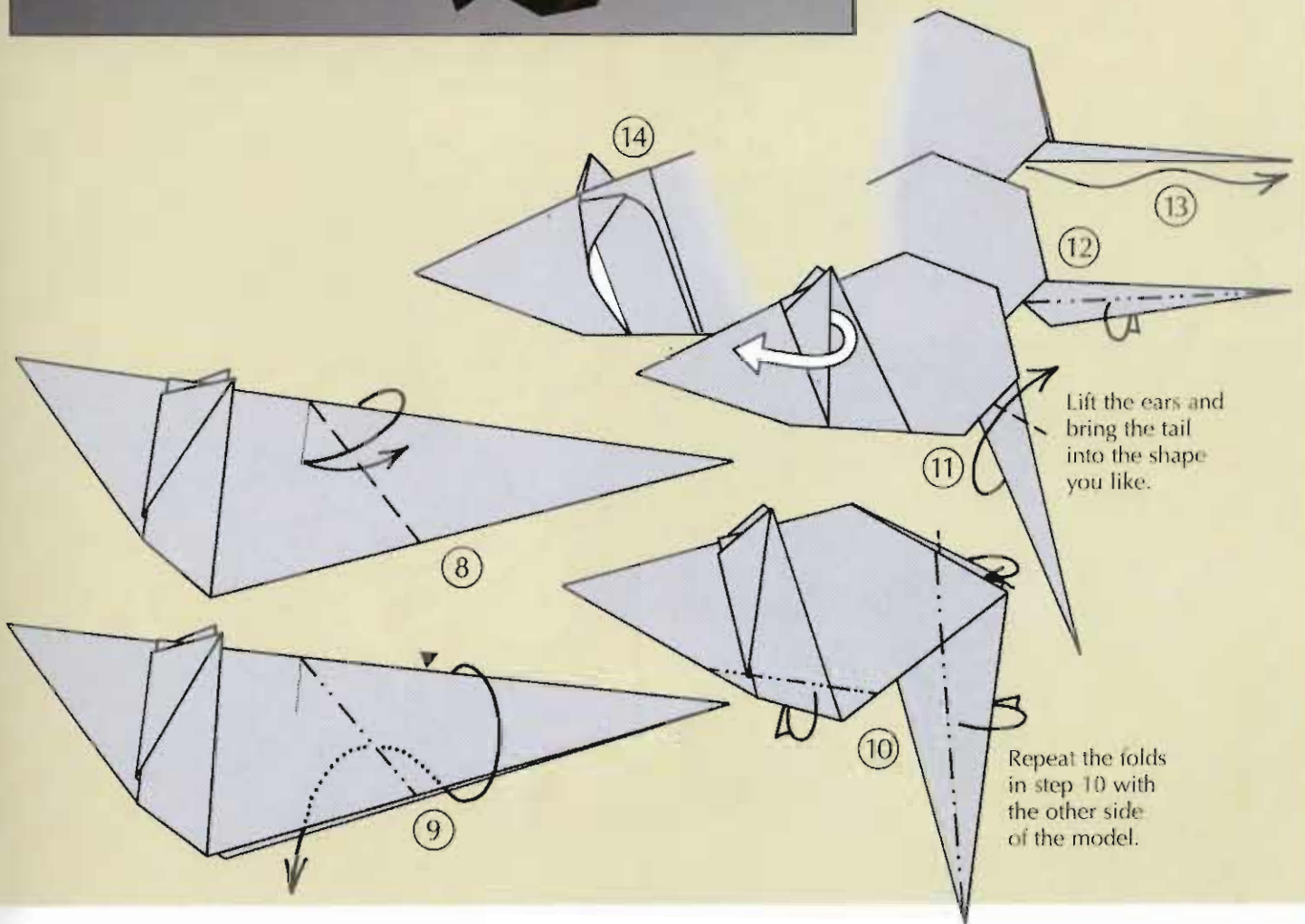
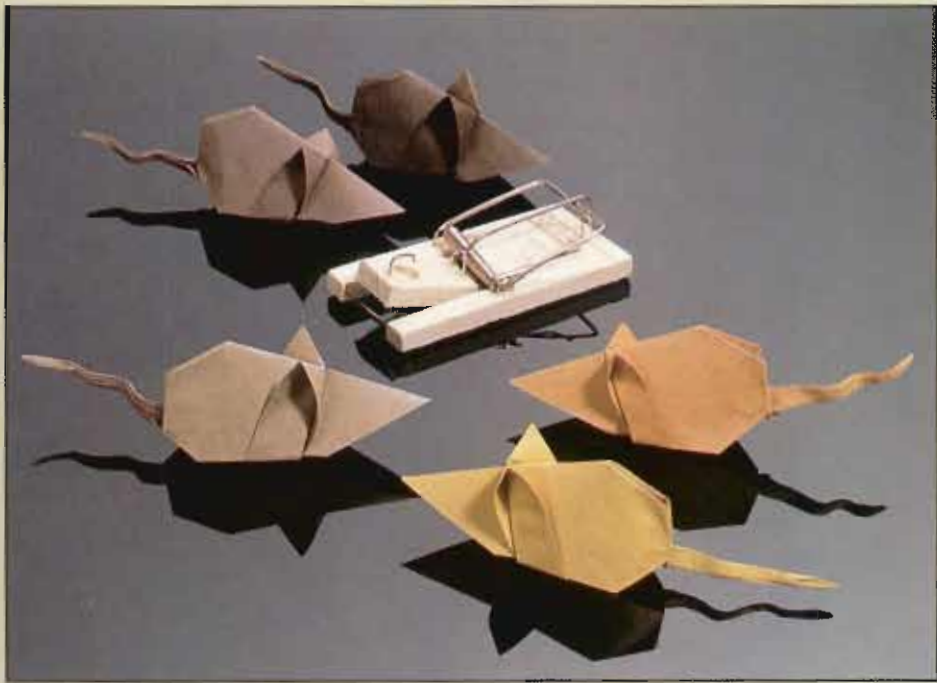

Panda

KUNIHICO KASAHARA

The size of the paper for the head and for the body is identical.

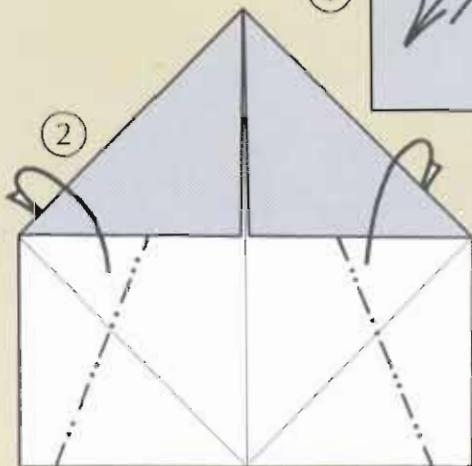
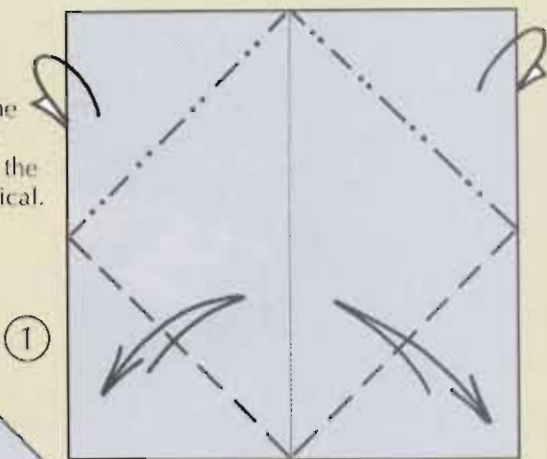

Head

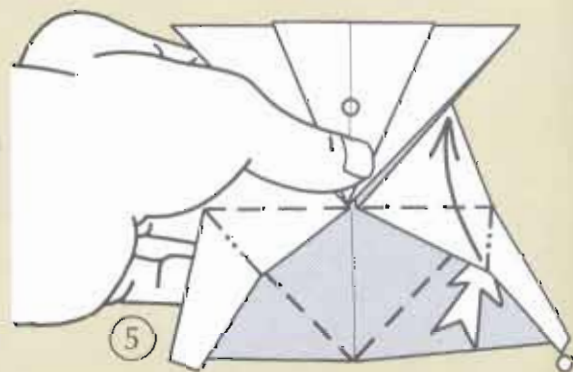
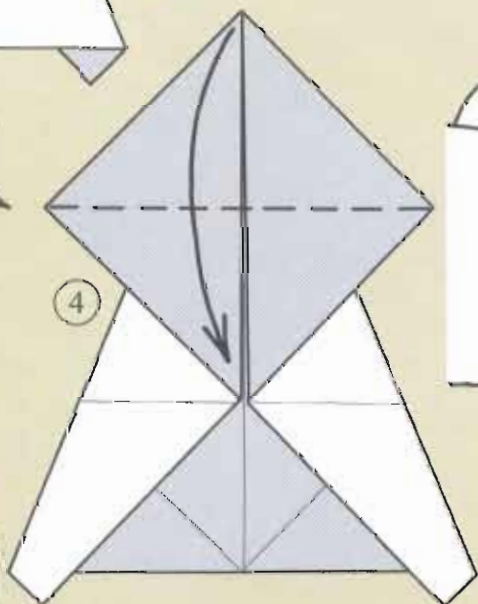
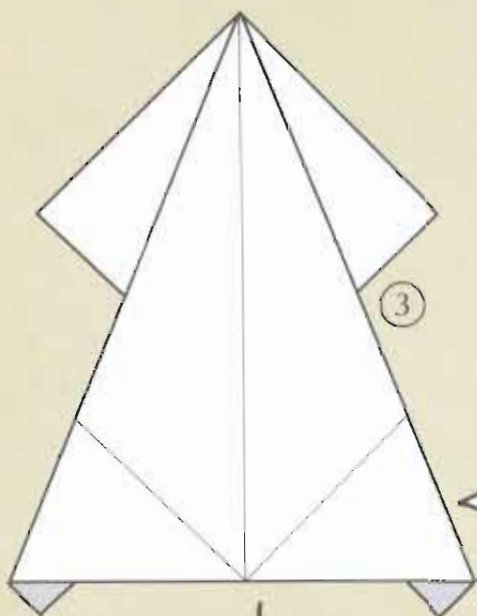

Repeat the fold on the left side.

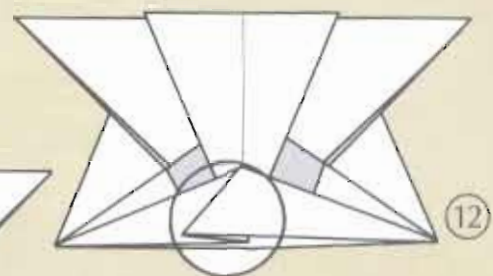
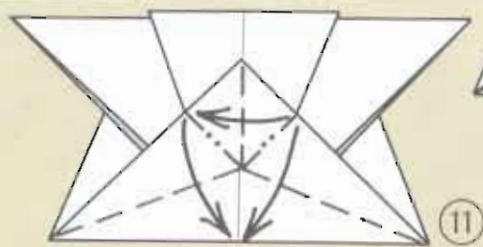
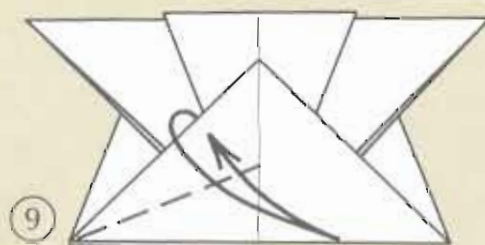
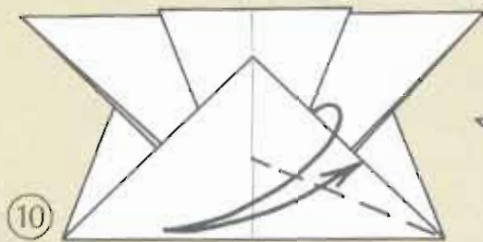
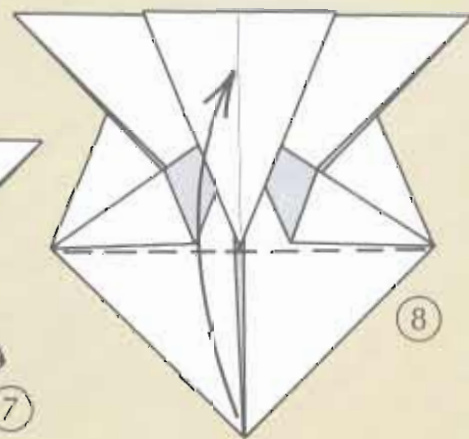
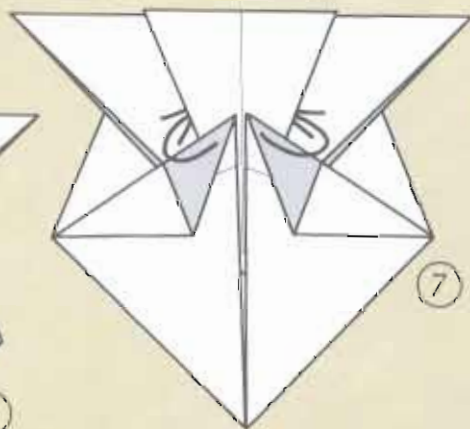
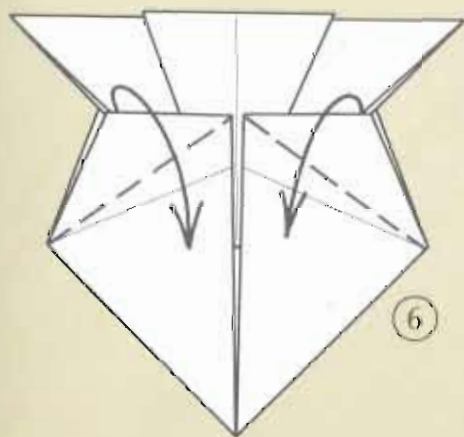

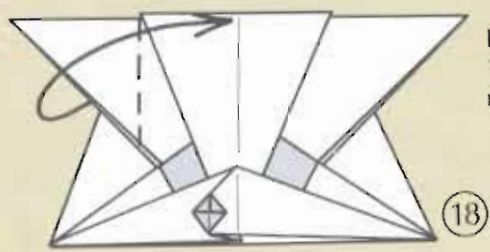
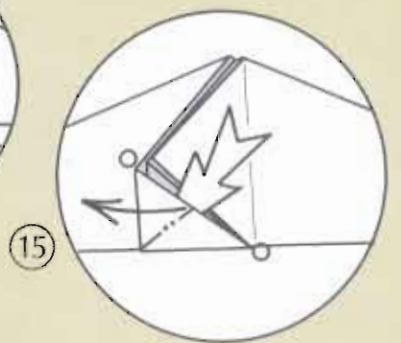
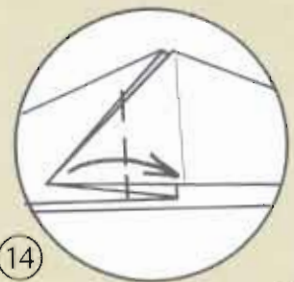
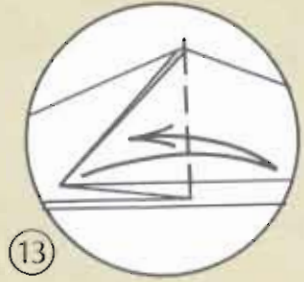

Repeat steps
18-20 with the
right ear.

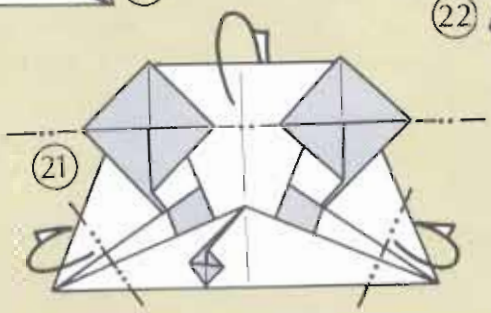
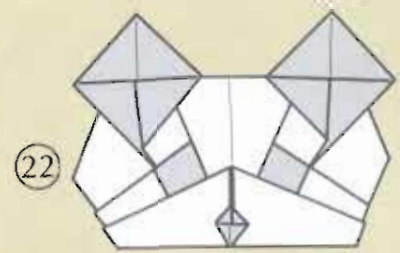
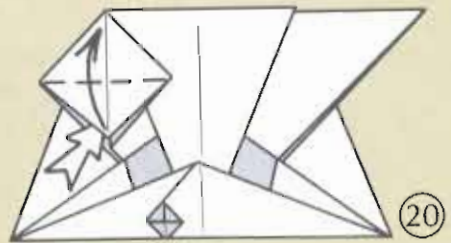
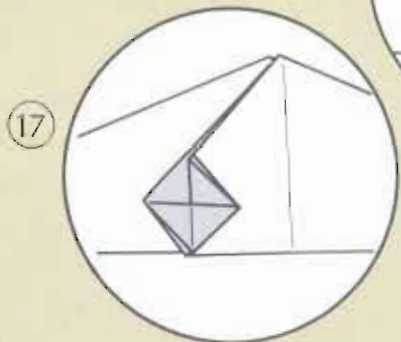
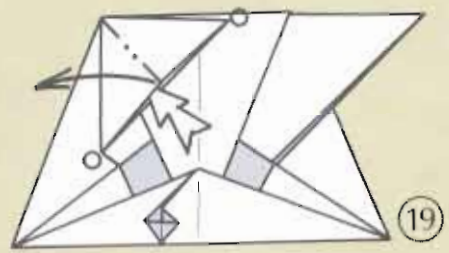
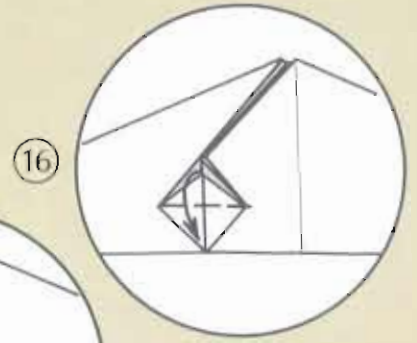

Body

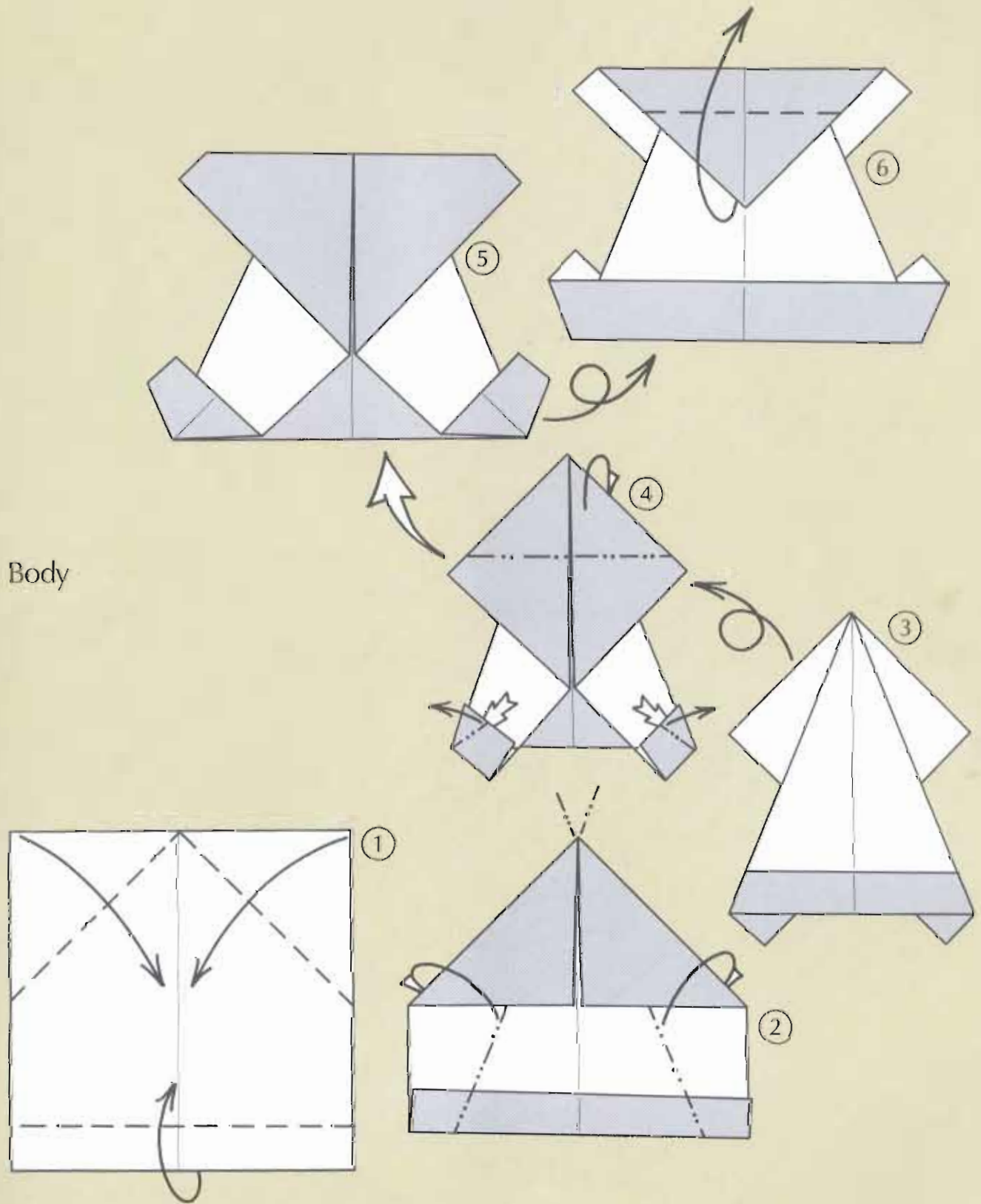

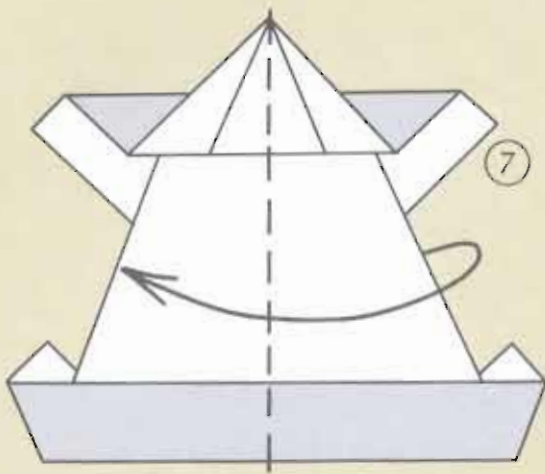

Tuck the body up, in between the layers of the head, into the position you like.

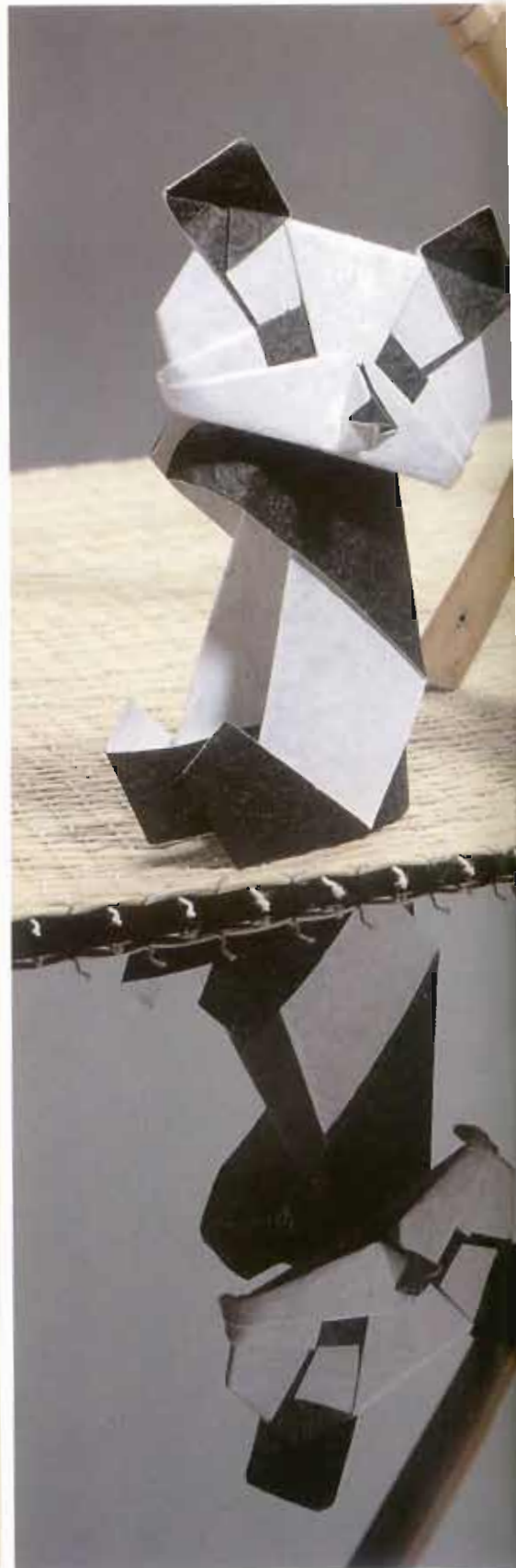
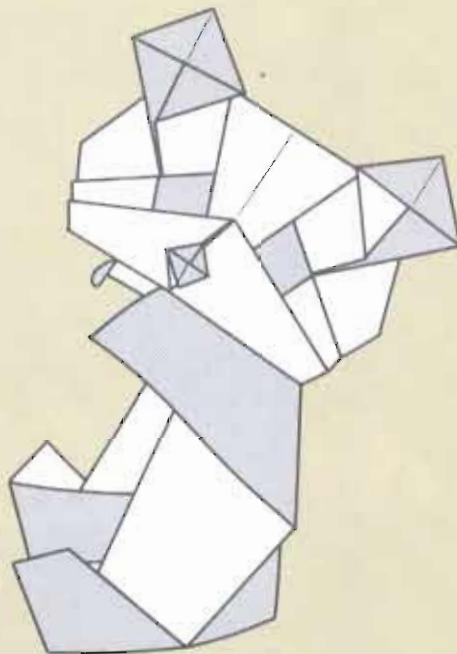
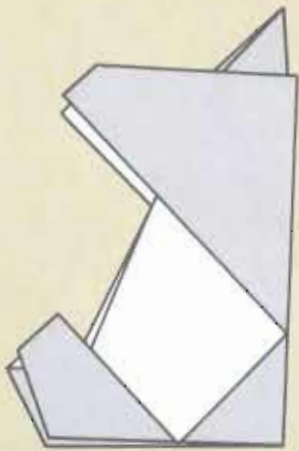
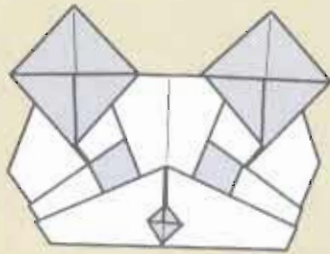



For a
Desk Top



Picture Frame

LARRY HART

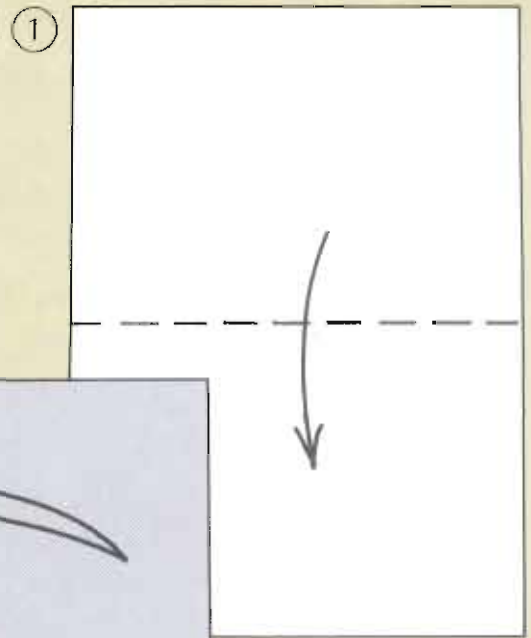

Starting size: 11.6 x 8.25 in
(29.7 x 21 cm)

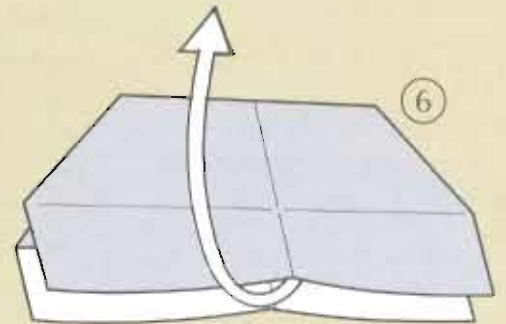
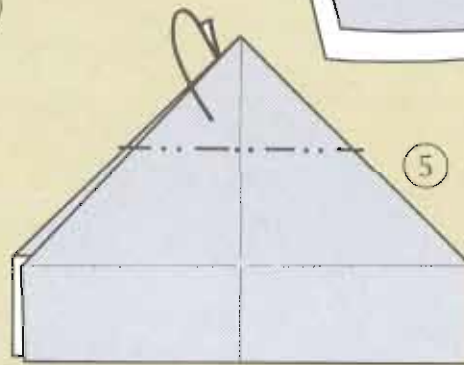
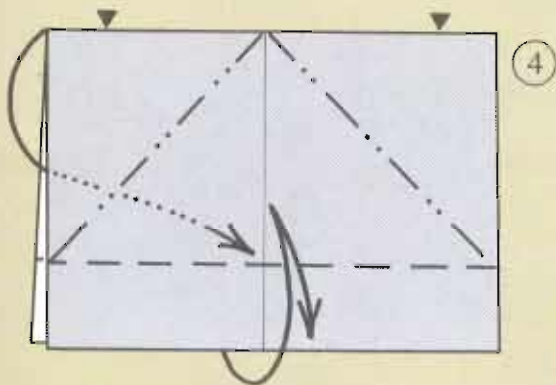
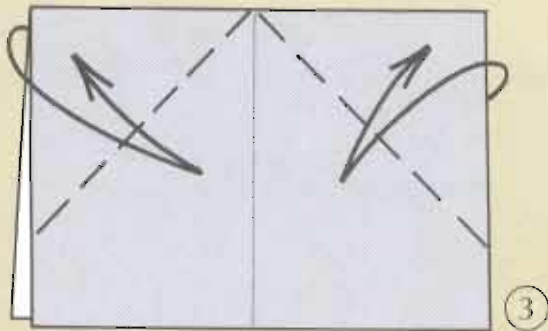
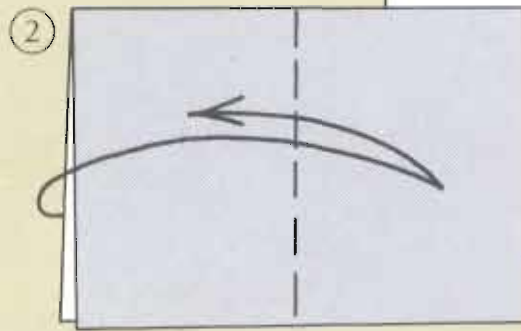

In steps 9 and 10 fold the horizontal and vertical edges to correspond with the size of the picture to be framed. The example shown here is a postcard, size 4 x 6 in (10.5 x 15 cm).

Take out the picture after you have folded the creases in step 10.

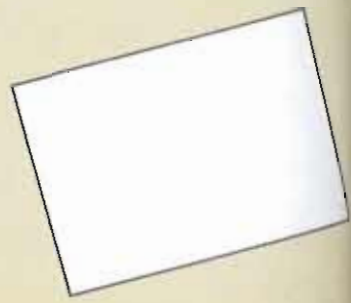
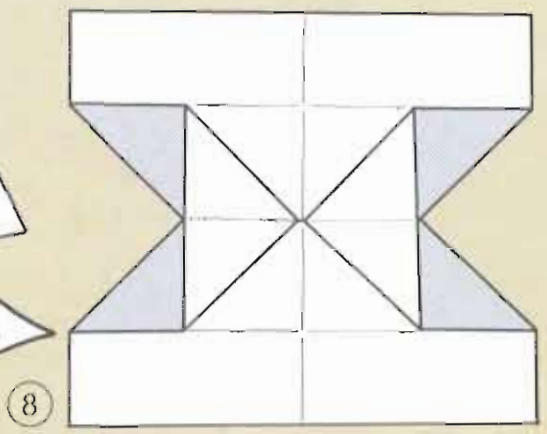
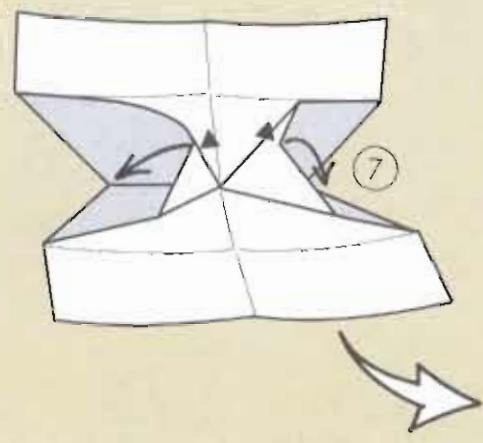
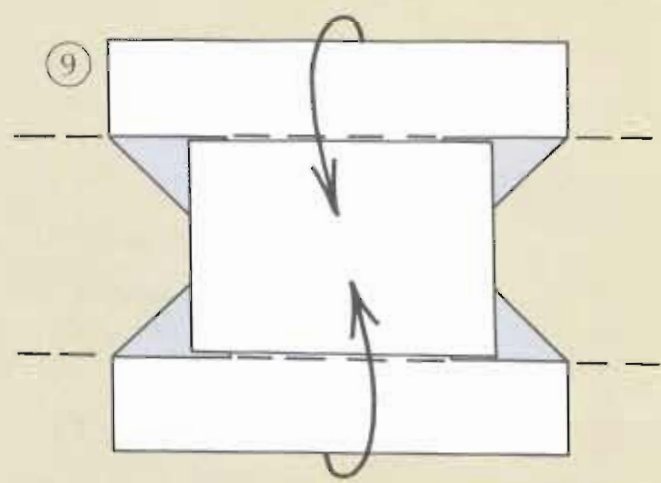
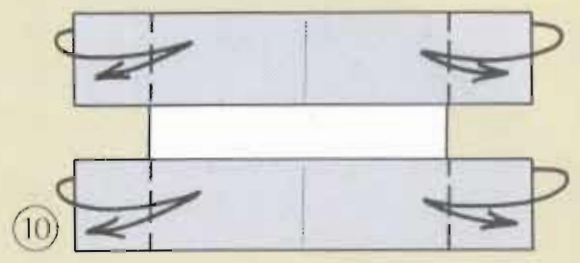

Place the picture you want in the frame in the center of the folds.

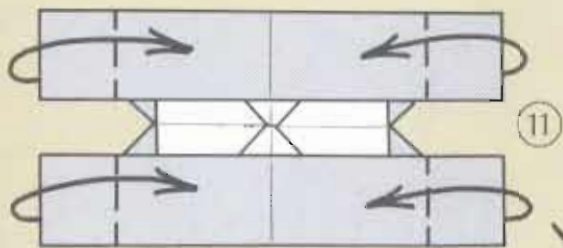

Fold the sides as shown in step 11 and then ...

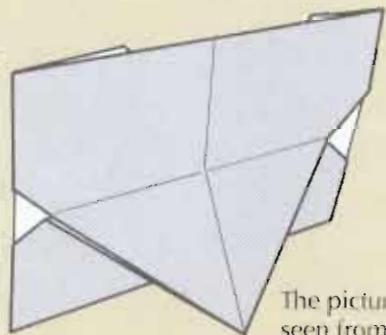

The picture frame seen from the back.

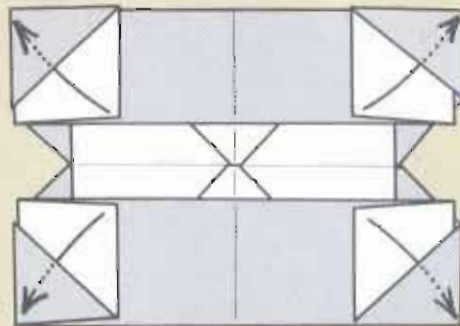

... place the picture inside the edges. Finished!



Note Book

MARTIN WALL

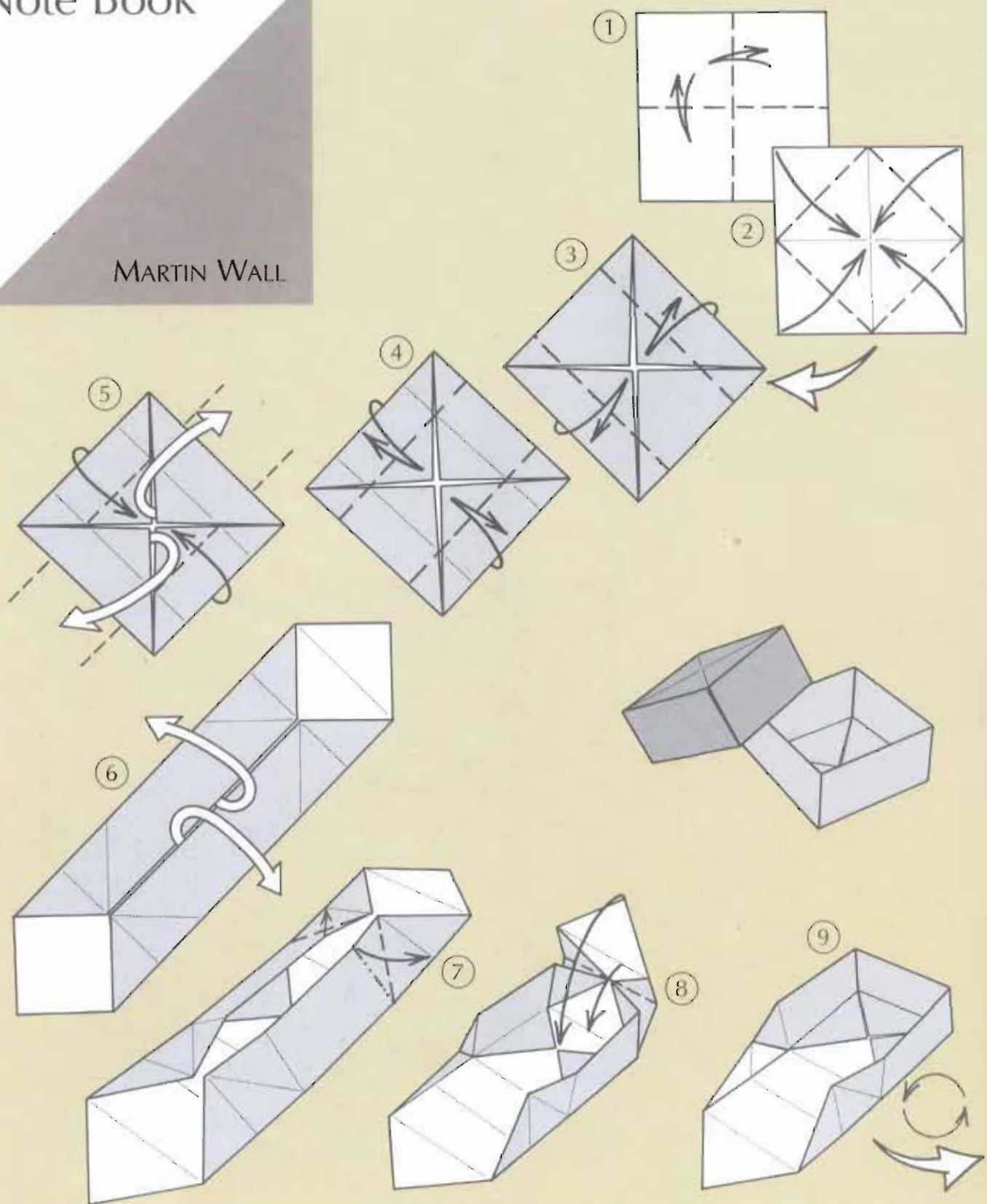

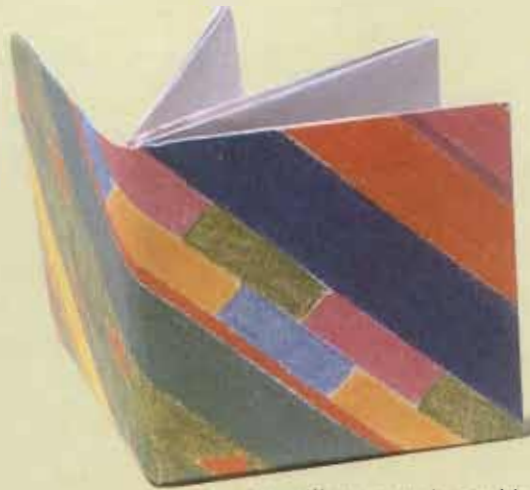

You will get a traditional box when the folds in step 8 are repeated on the other side in step 9. If you skip step 9 and continue with step 10, you will get the note book as the final result. However, in this case, the paper has to be placed with the folds upward in step 1.

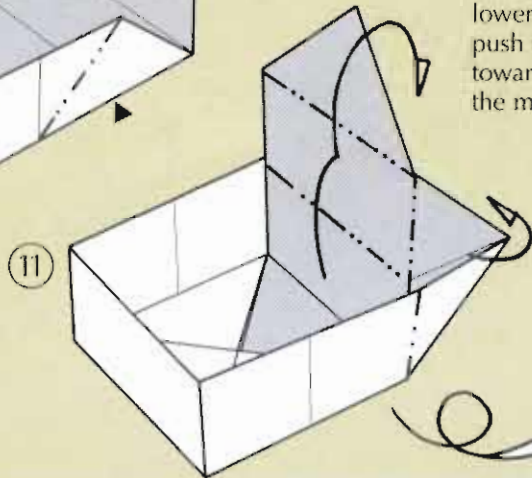
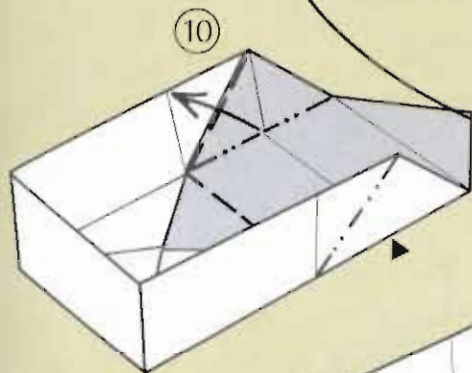
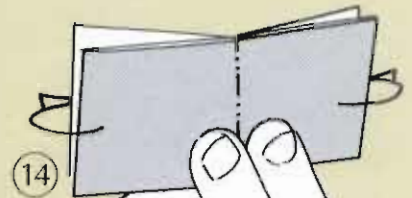
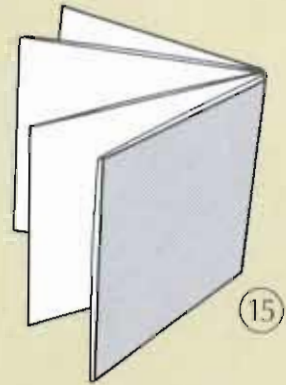

Simultaneously, lower the center and push the two sides toward the center at the marked areas.

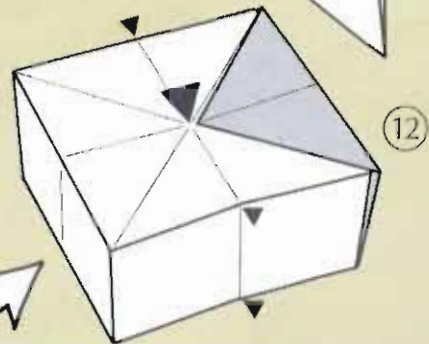
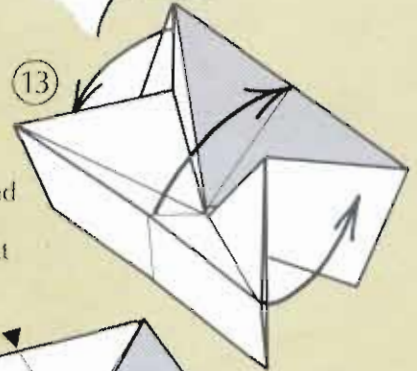

Container

GIUSEPPE BAGGI

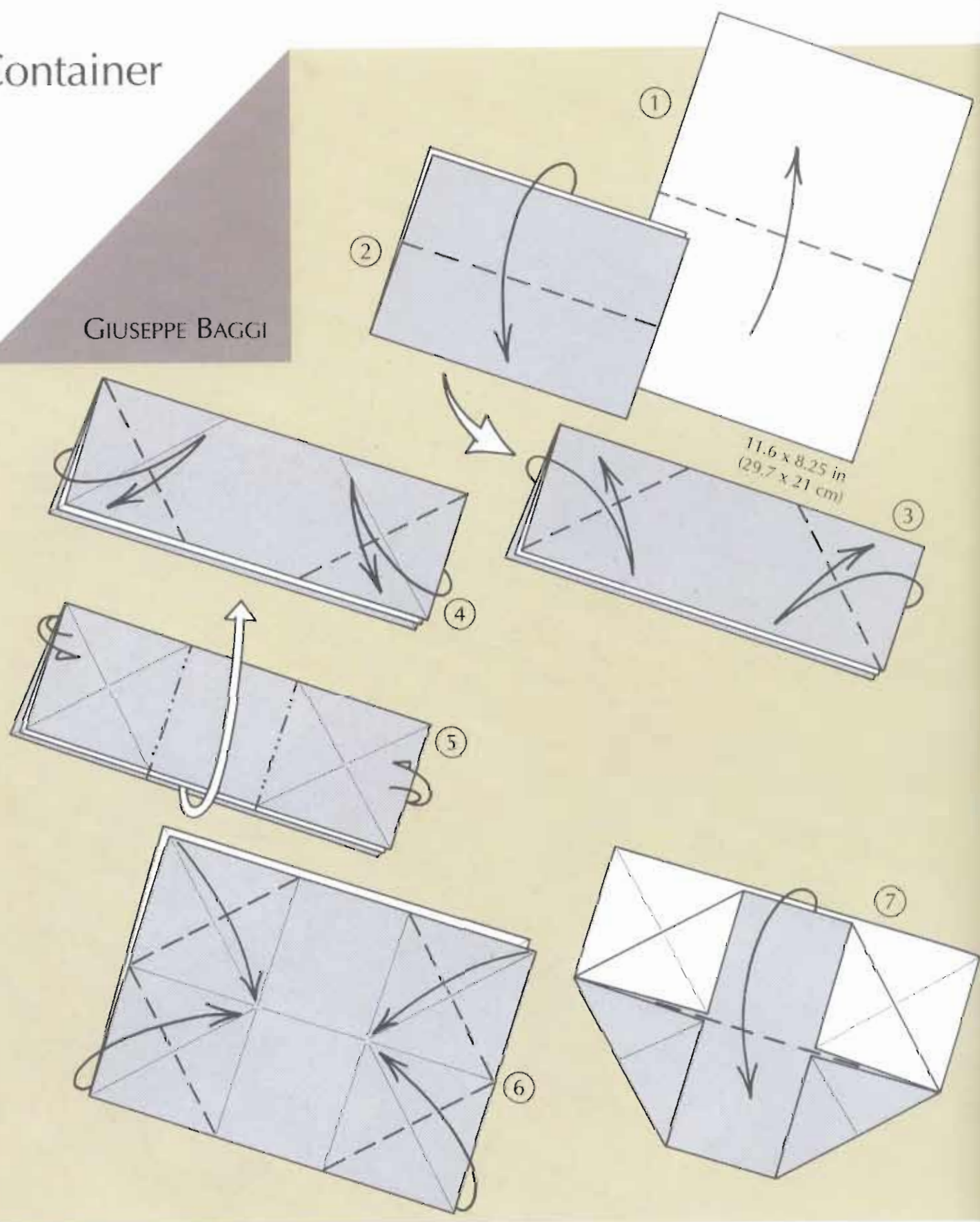

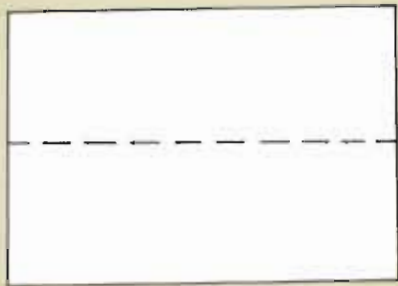

This container is the final result when the paper is not divided diagonally but lengthways in step 1 and the remainder of the steps are carried out with the new starting base.

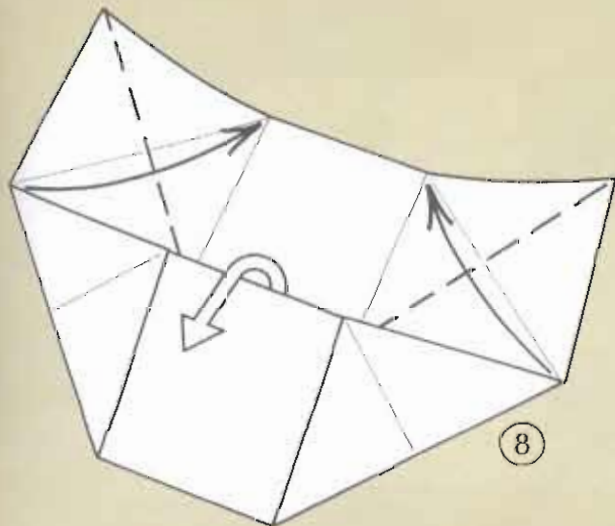

8

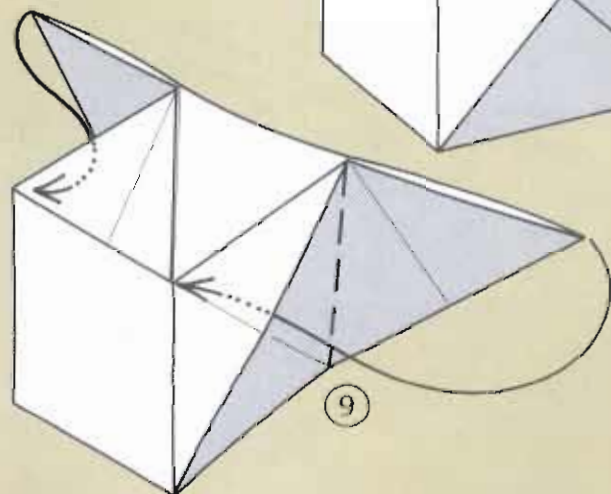

9

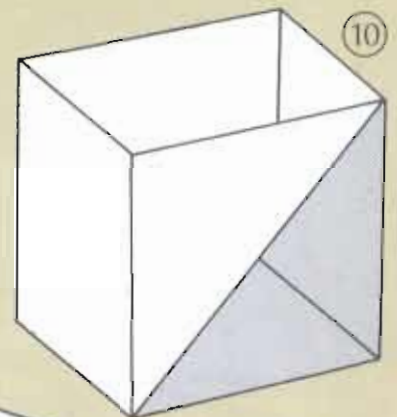

10

Folder

HUMI HUZITA

39 in (100 cm)

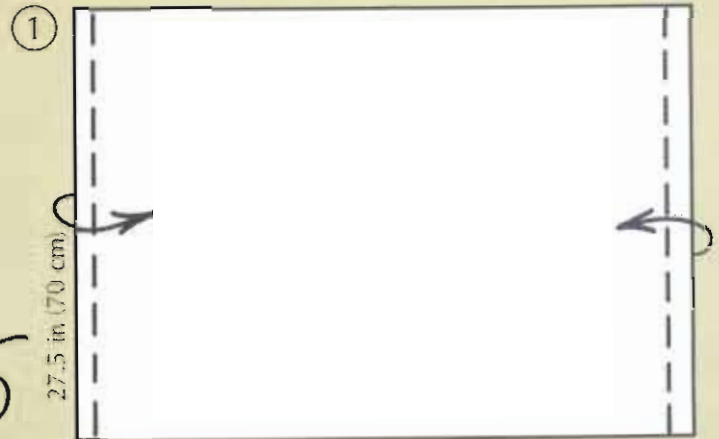

27.5 in (70 cm)
1.4 in (3.5 cm)

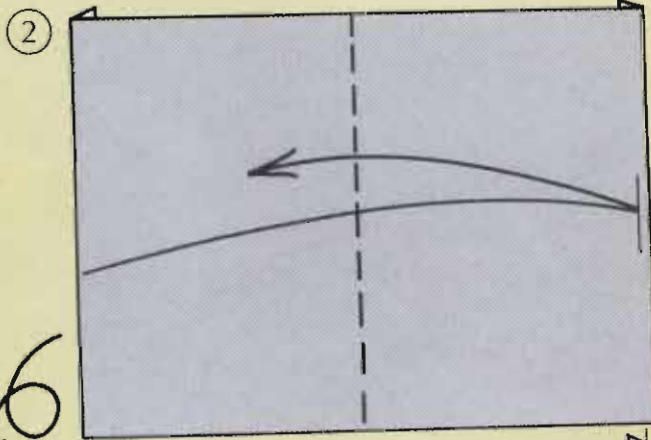

Repeat step 2 on the other side. These two folds will produce a spine of 0.4 in (1 cm) thickness for the folder.

0.4 in (1 cm)
0.4 in (1 cm)

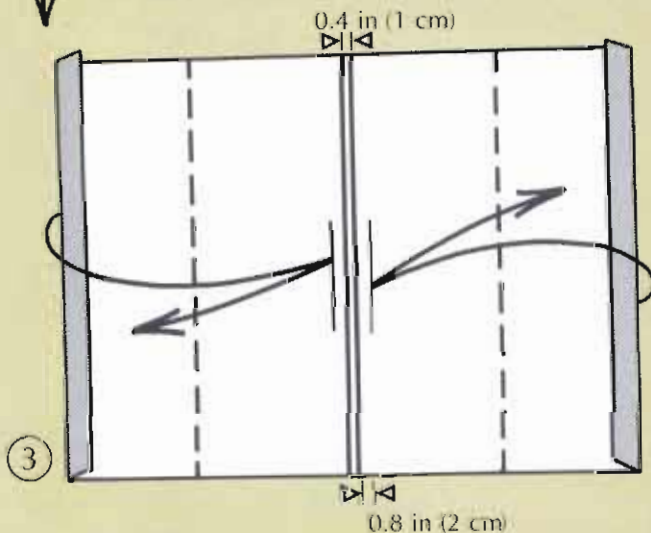

3

0.8 in (2 cm)

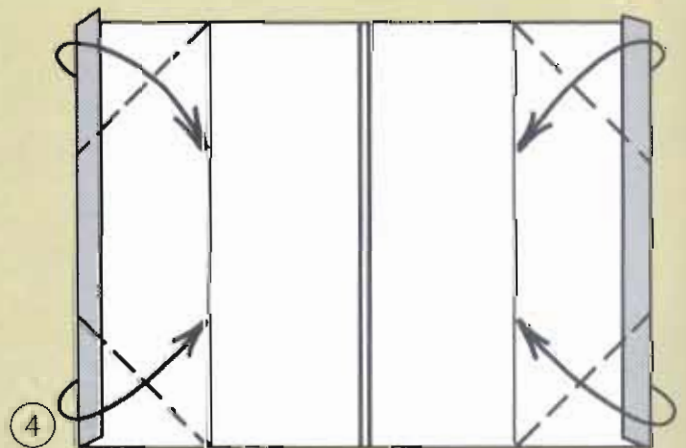

4

This folder by Professor Humi Huzita is an outstanding example of an "Origami Design Line". This model is ideal because of the logical steps throughout its folding sequence and the useful object that results. The combination of folding sequence, design and utility value is Professor Huzita's main objective.

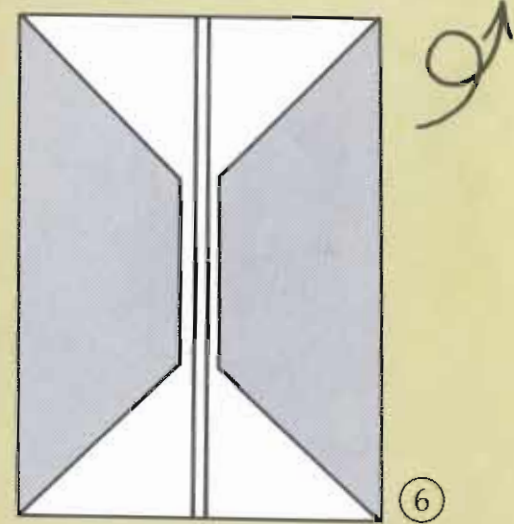
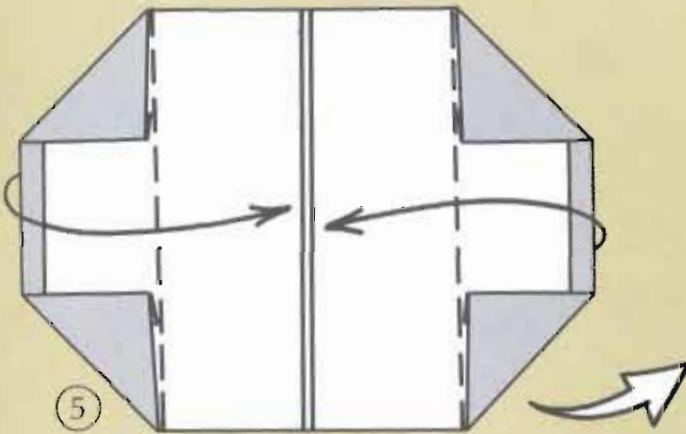
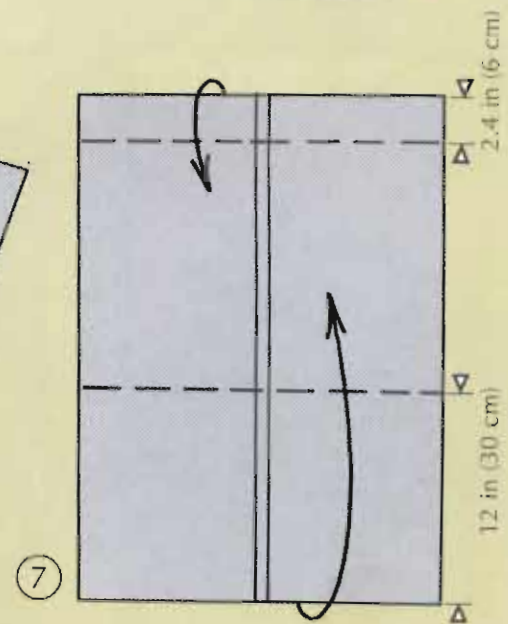
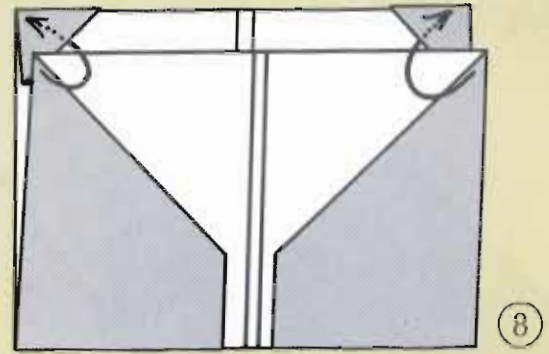
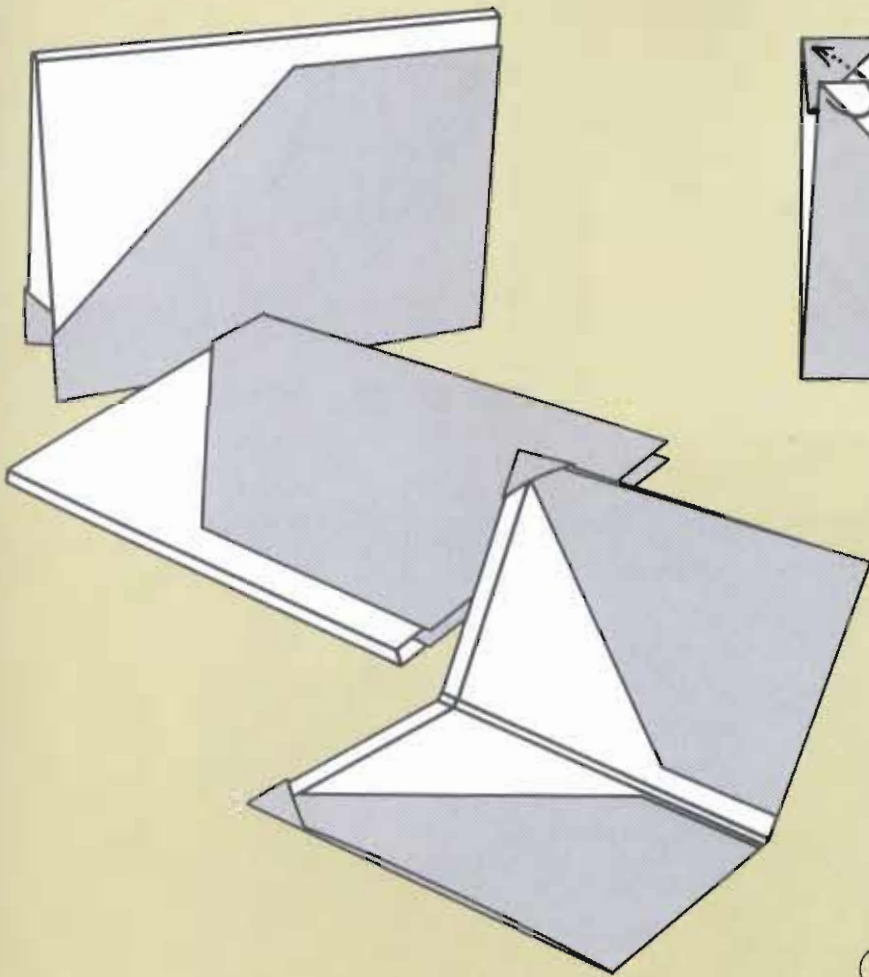

Daisy's Envelope

NICK ROBINSON

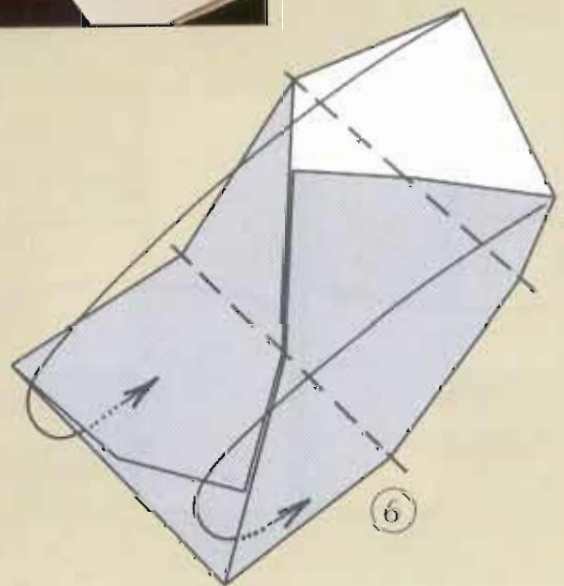
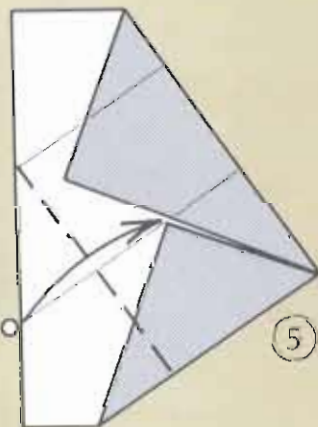
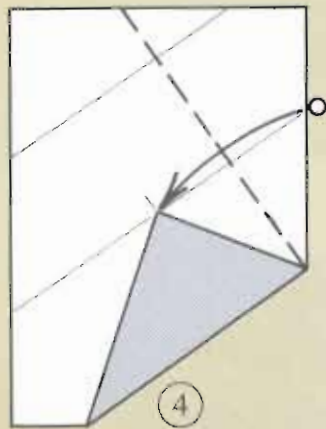
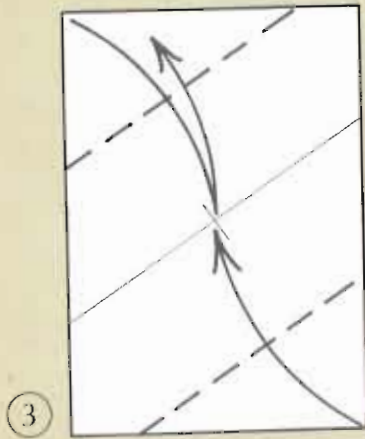
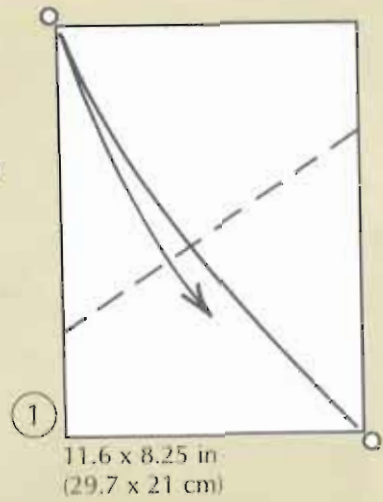
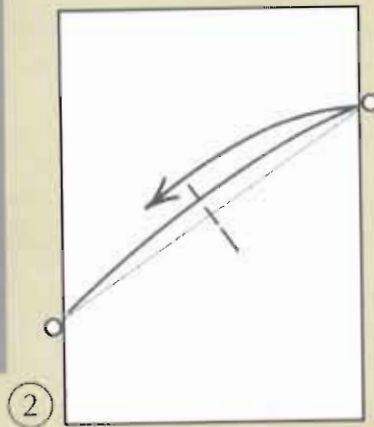

Nick Robinson named this envelope after his daughter.

Presenting Gifts



Bowl

PHILIP SHEN
attributed to

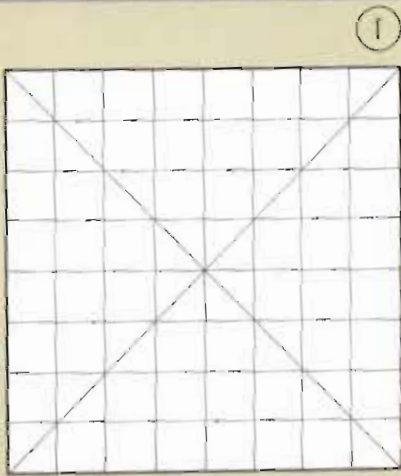

①

Firstly, make two diagonal creases at the front and a horizontal and vertical division at the back.

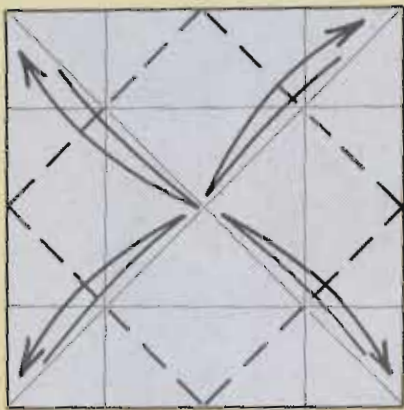

②

The creases made in step 1 will only be shown for practical reasons in the following instructions.

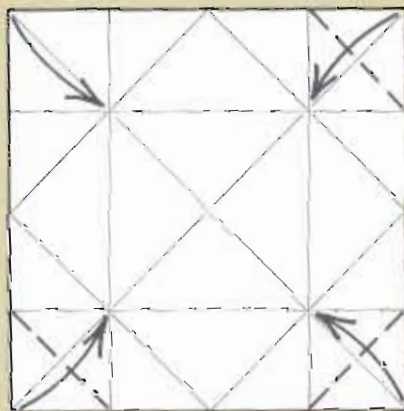

③

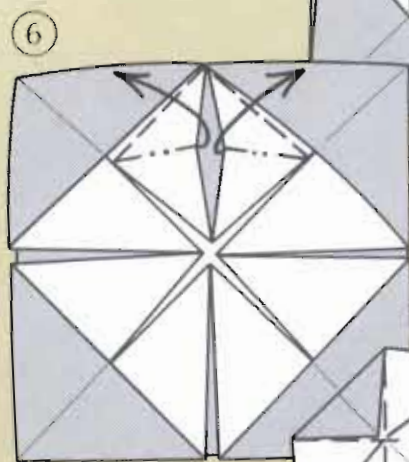

⑥

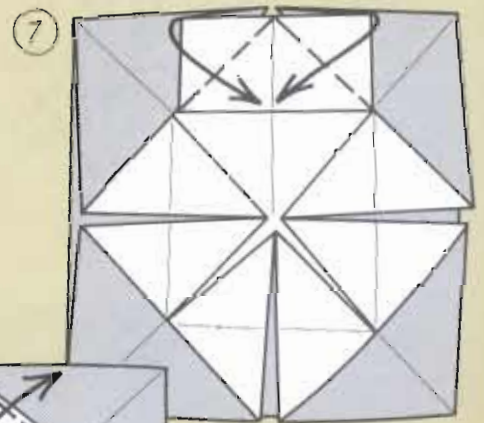

⑦

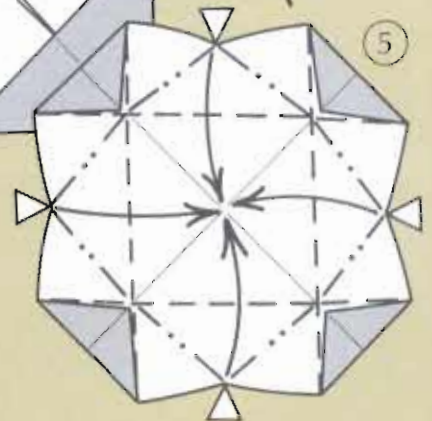

⑤

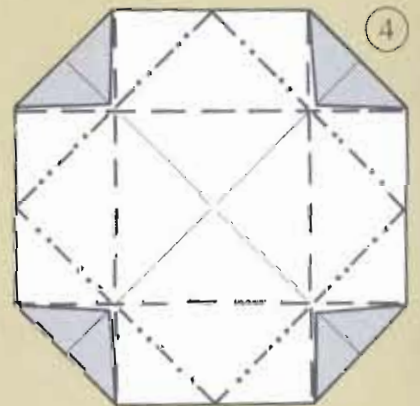

④

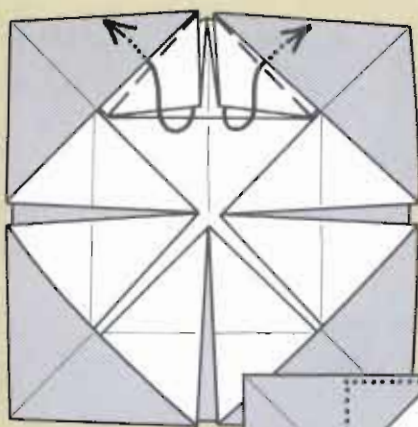

8

Repeat steps 6-8 on the other corners.

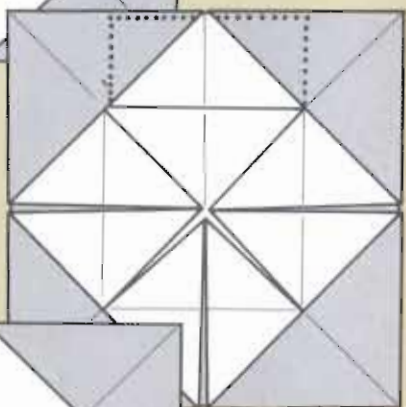

9

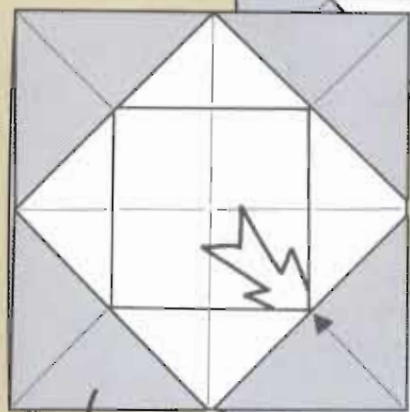

10

Take the marked corner area tightly between your finger and thumb. Then make the creases from the bottom with the other hand as shown in step 11. The bowl will now take shape. Repeat on all corners.

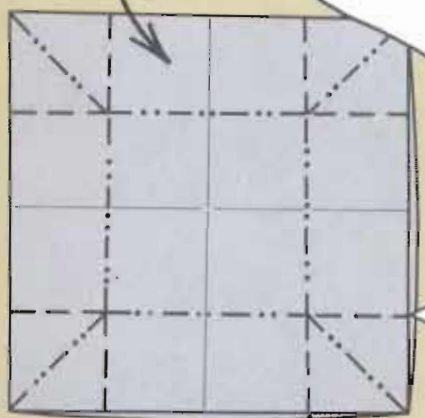

11

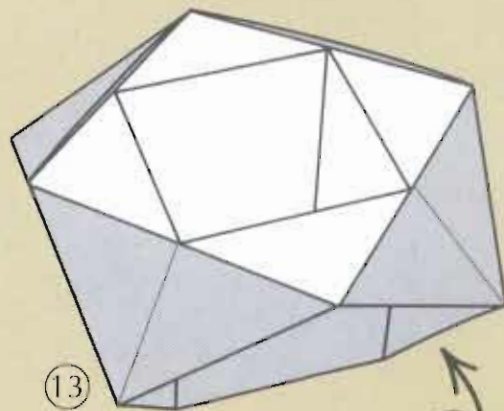

13

The model seen from the back.

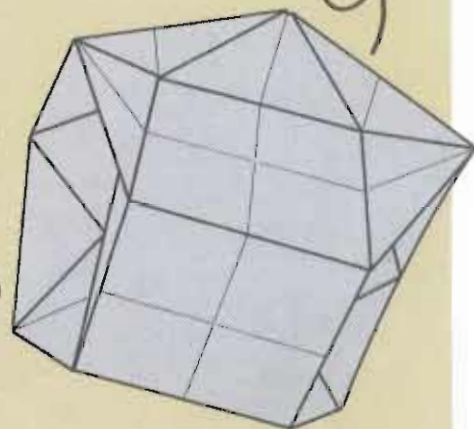

12

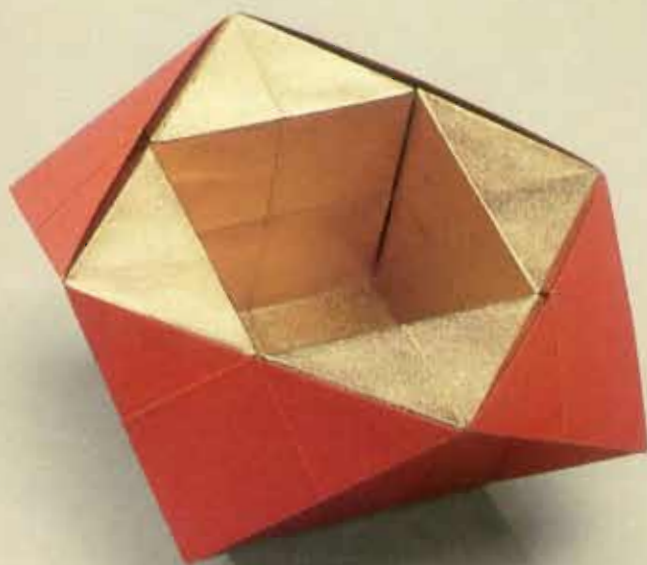

Gift Box

GIOVANNI
MALTAGLIATTI

Paper size: you need a relatively large square for the gift box. For instance, if the completed box should have an edge of 2.4 in (6 cm), the paper size needs to be 9.8 x 9.8 in (25 x 25 cm).

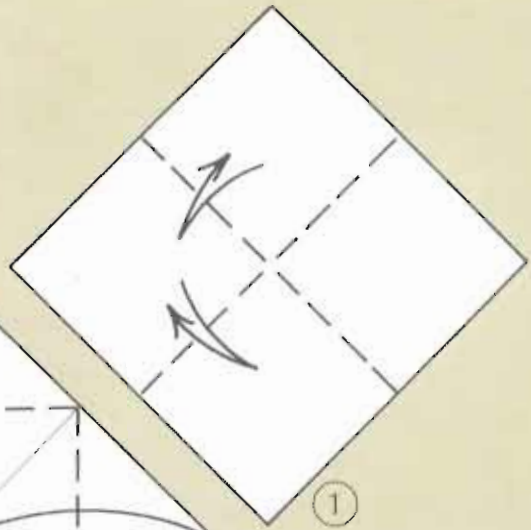
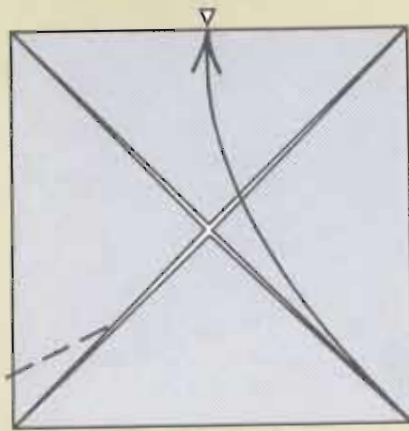

Do not make the crease shown in step 3. It only serves to establish where to divide the paper in three equal parts.

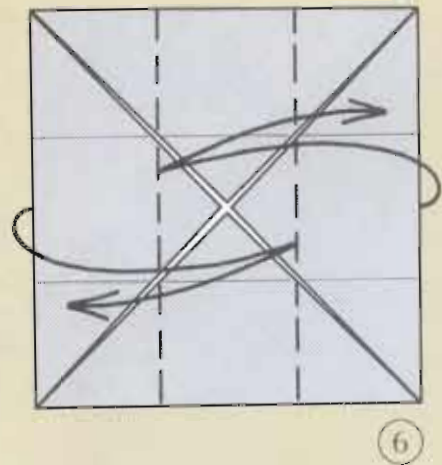
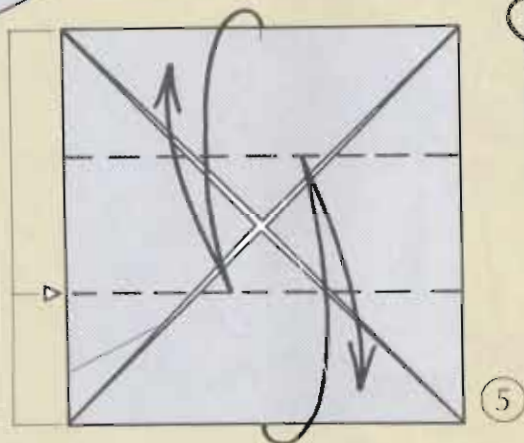
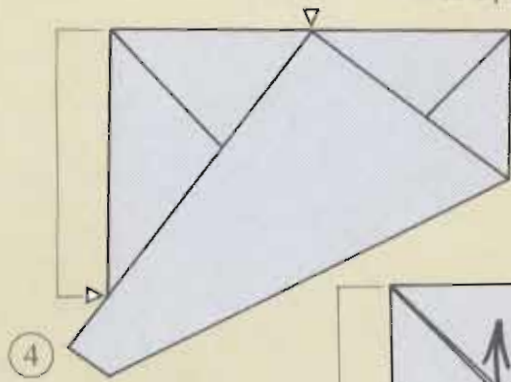

Repeat steps 8-11 on all corners.

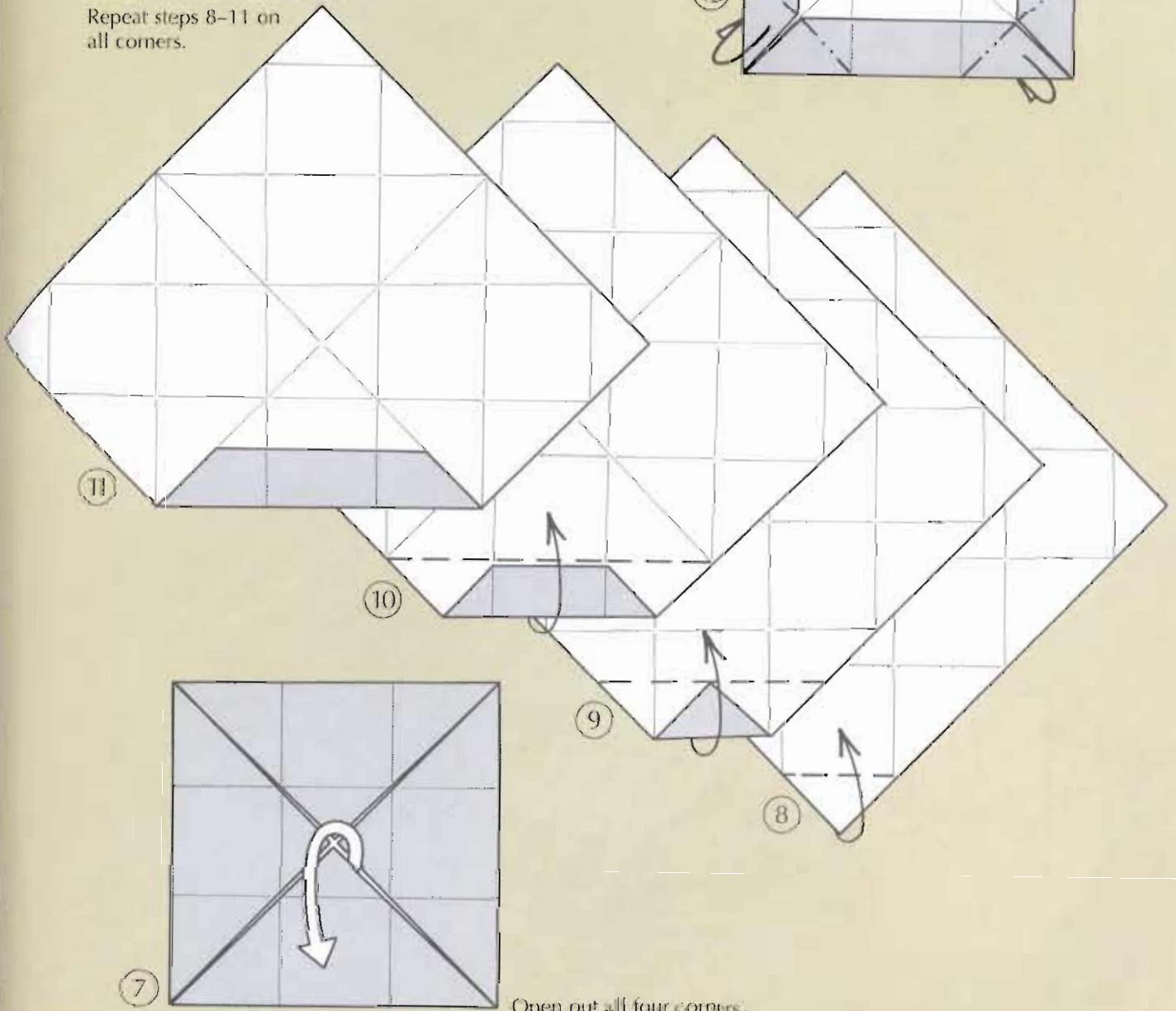

Open out all four corners.

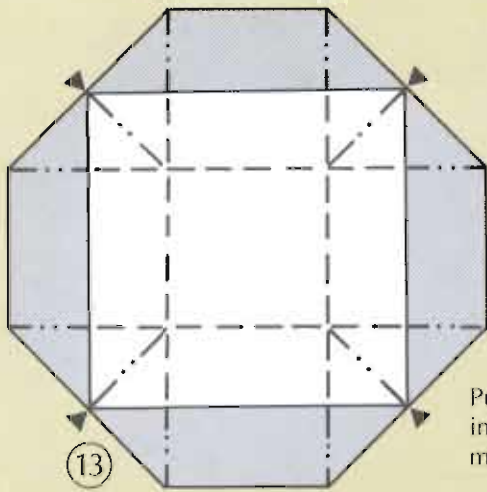

13

Push the box to the inside and lift the marked areas.

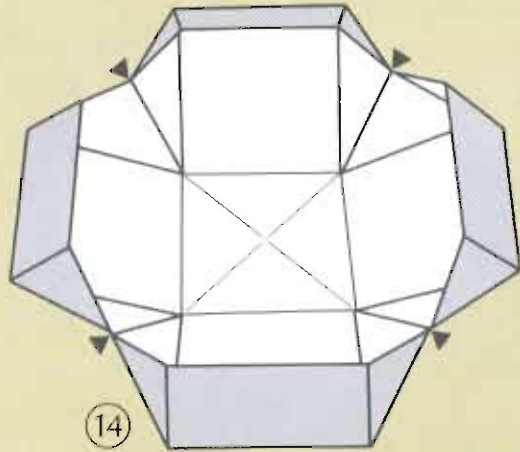

14

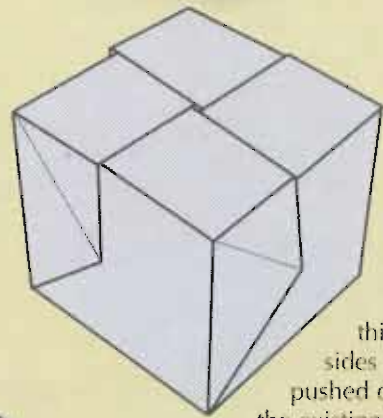

You will get this lid when the sides are alternately pushed over and under the existing adjacent side in step 15.

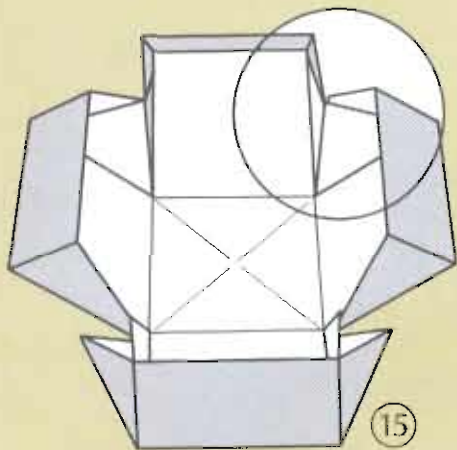

15

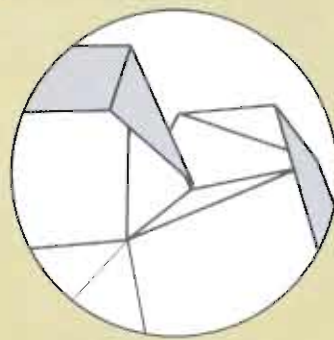

You will get this lid when the two opposite sides are pushed under the other two sides in step 15.

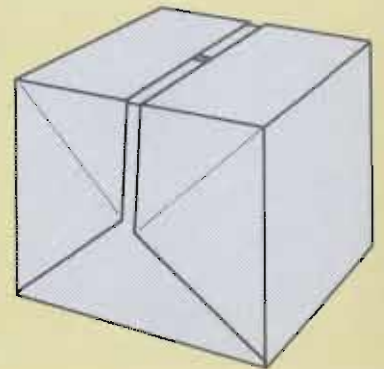



Christmas
Decorations

Star

PAOLO BASCETTA

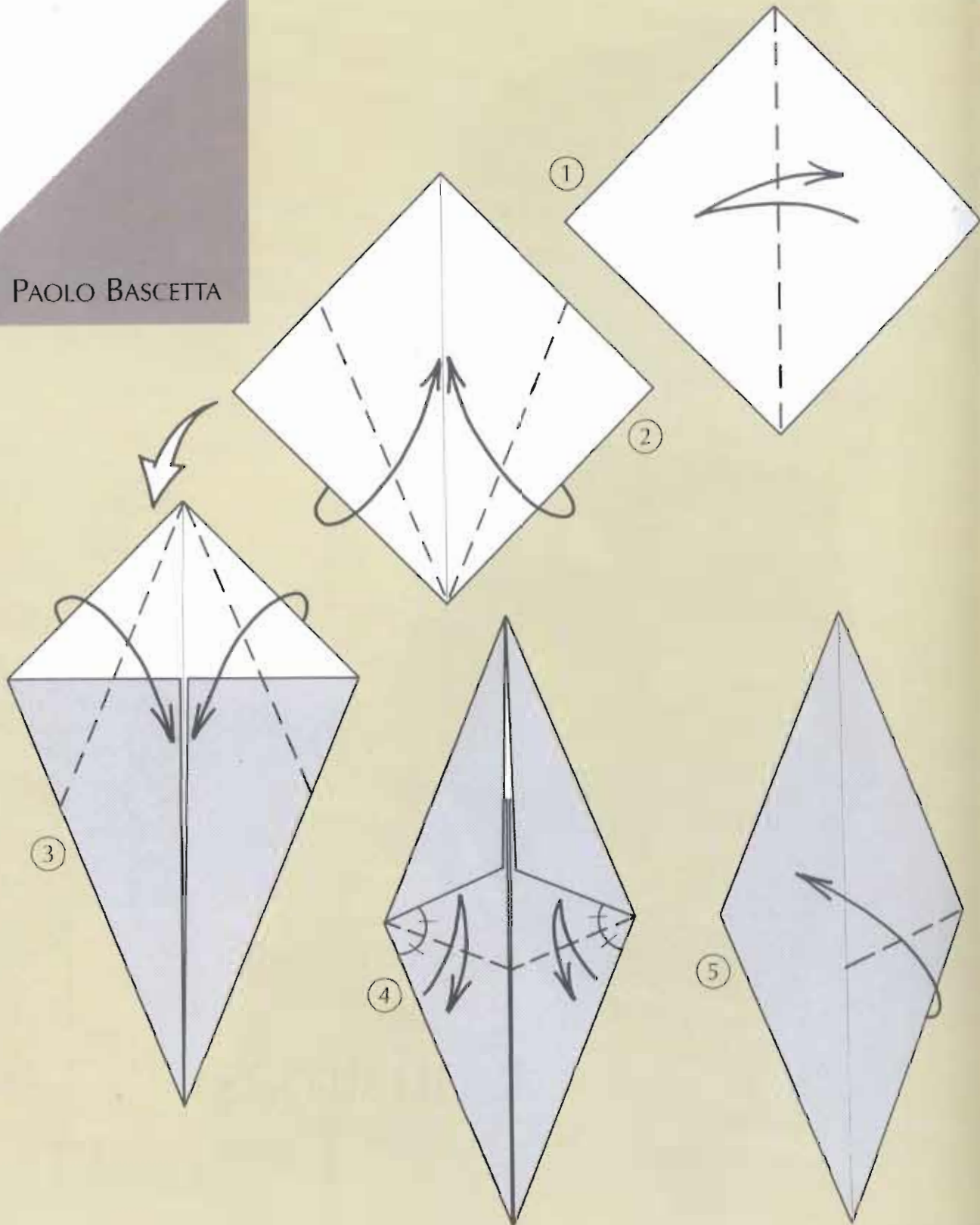

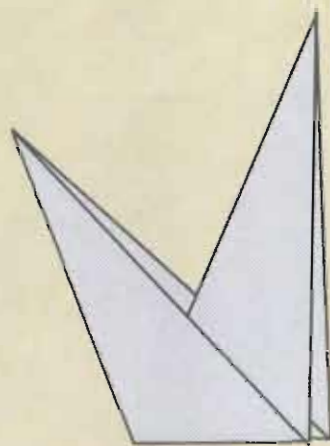
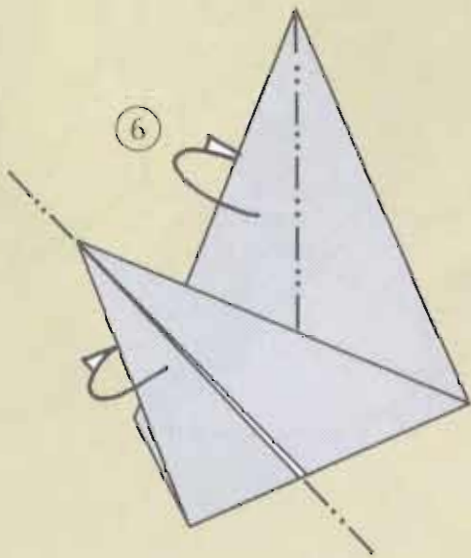
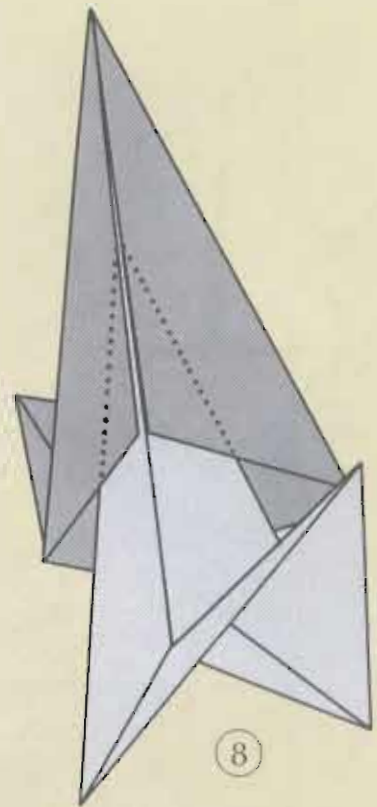

⑦ Fold 8 identical elements.

Put all the elements together as shown in step 8. The last element is the most difficult one to insert and requires much patience.

Angel

ALFREDO GIUNTA

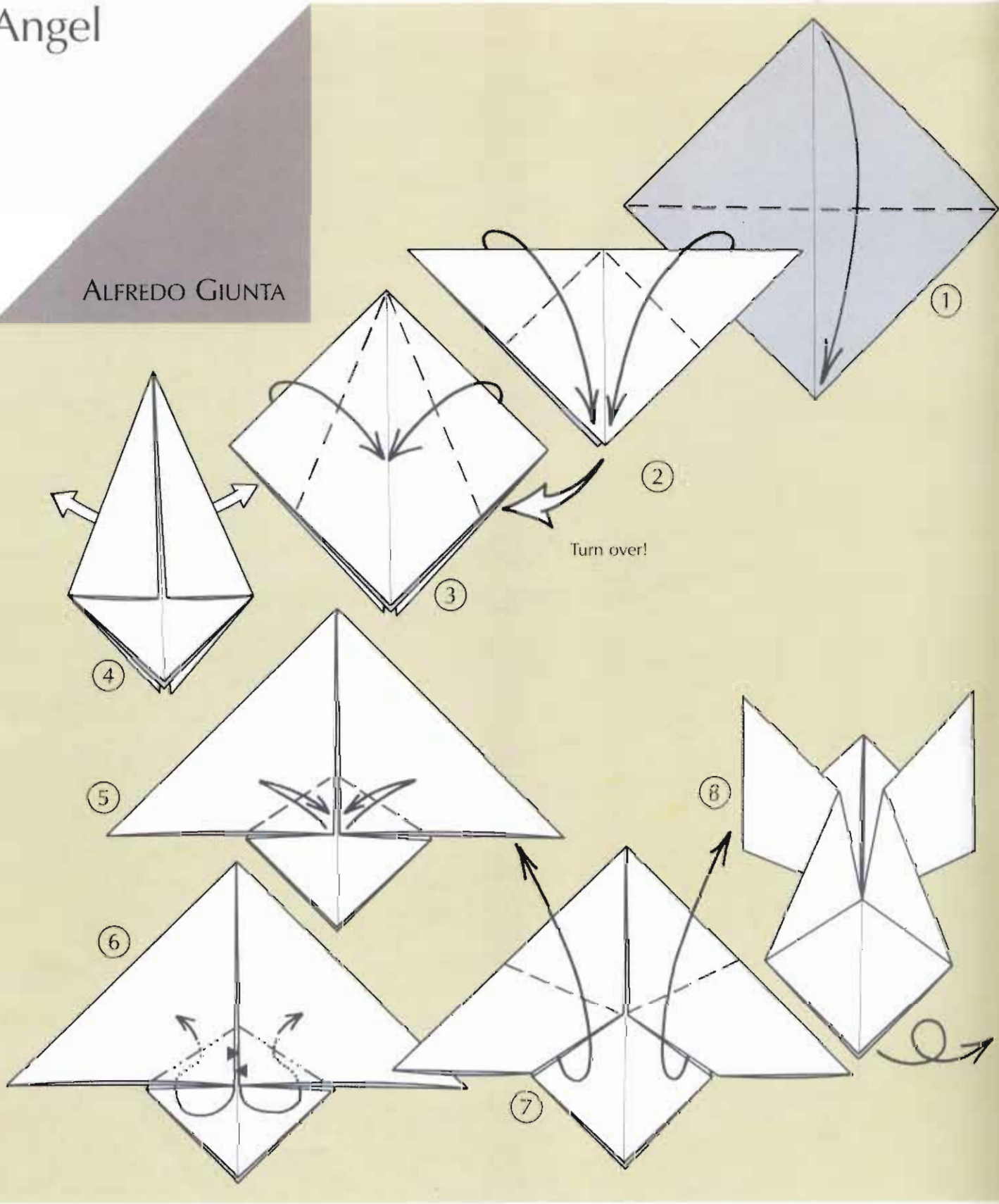

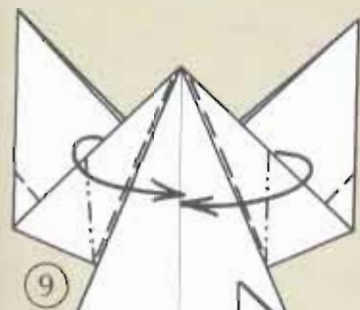

9

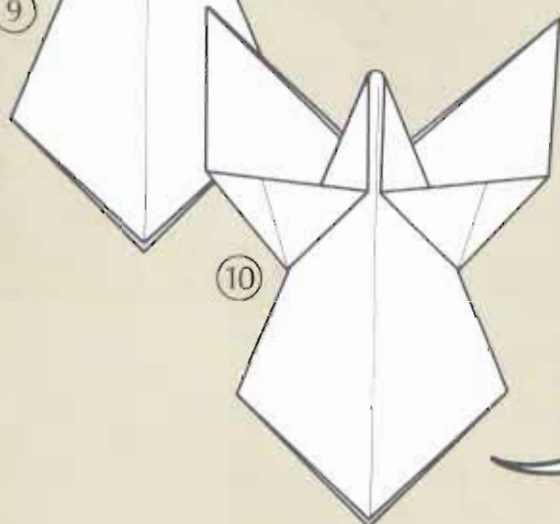

10

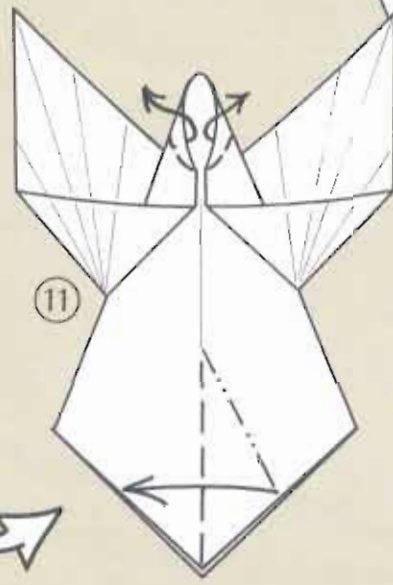

11

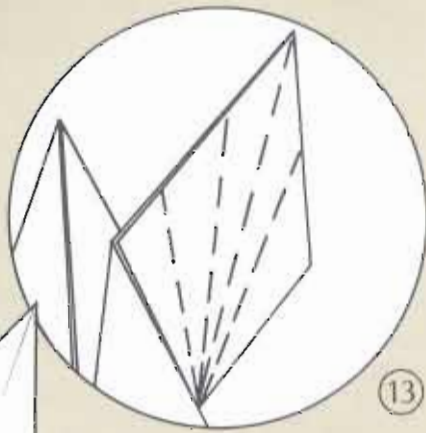

13

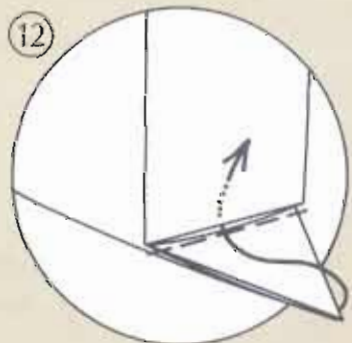

12

Valley fold the creases for the wing from the back of the model. They are optional and serve to curve the wing.

Decoration

SAM CUILLA

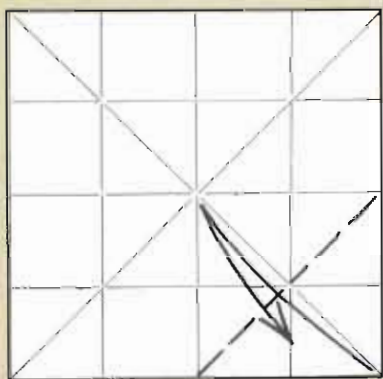
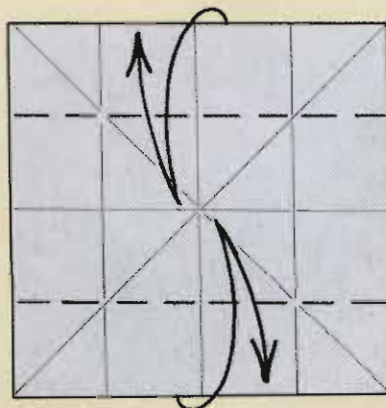
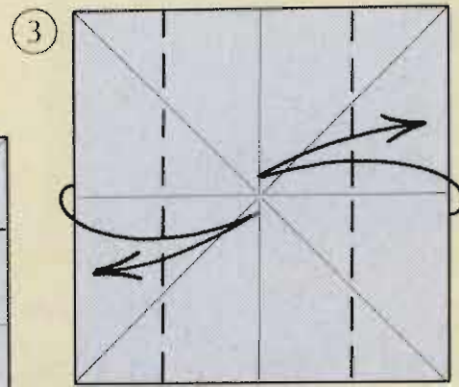
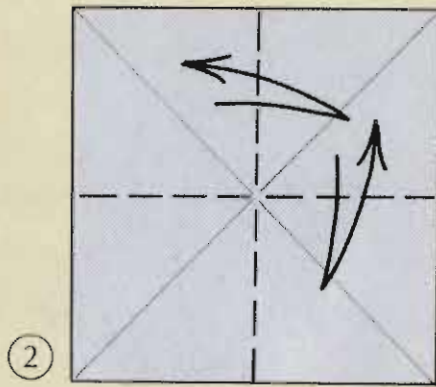
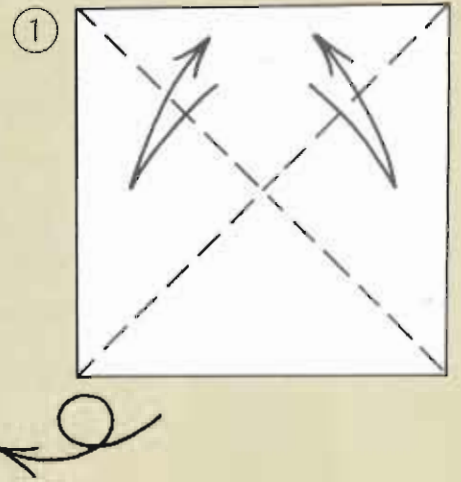

Repeat steps 5 and 6 on all corners.

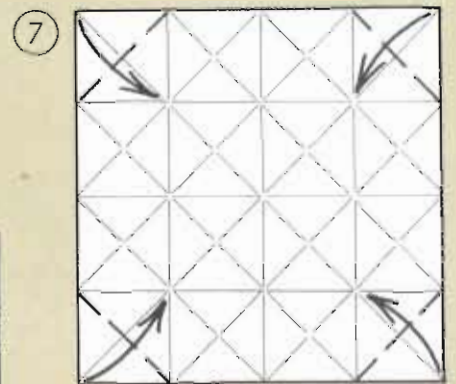
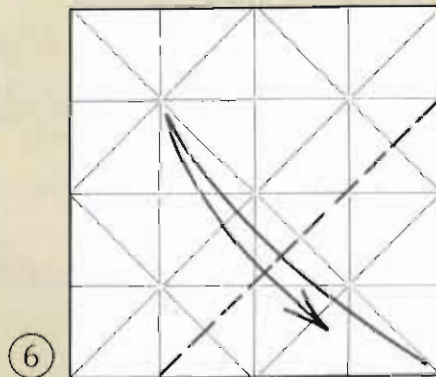

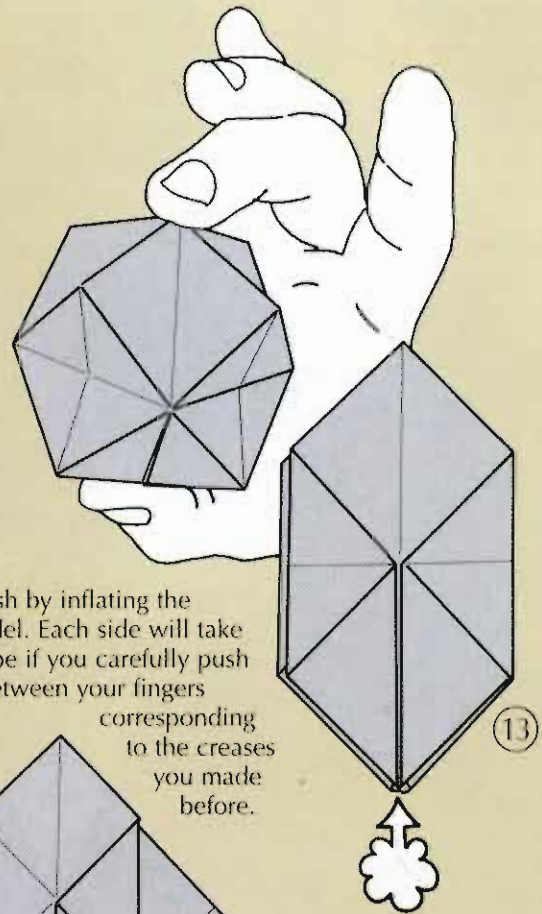

Finish by inflating the model. Each side will take shape if you carefully push it between your fingers corresponding to the creases you made before.

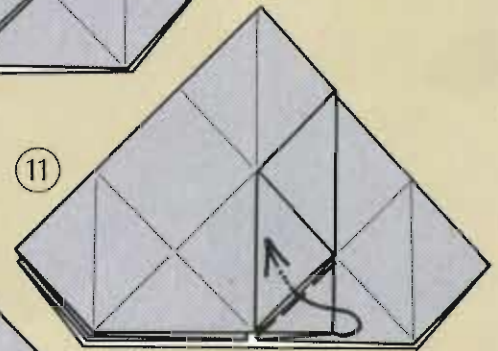
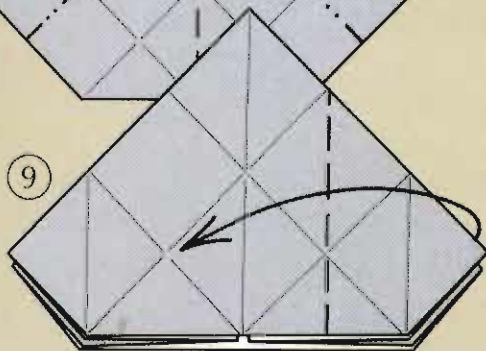
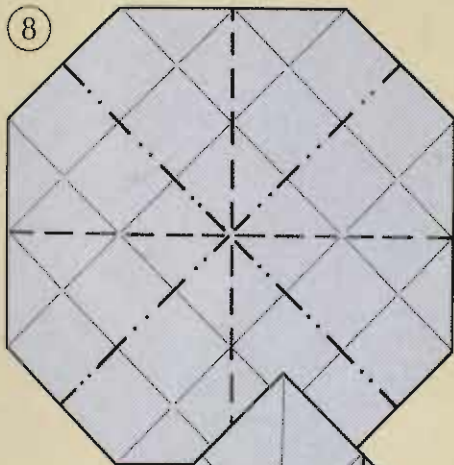

Repeat steps 9–11 three times.

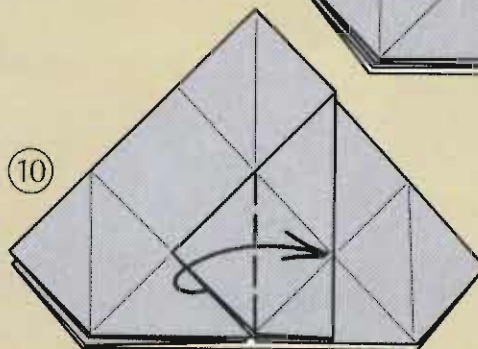

Tuck the corner into the pleat of the above lying triangle.

Happy Santa

JOHN SMITH

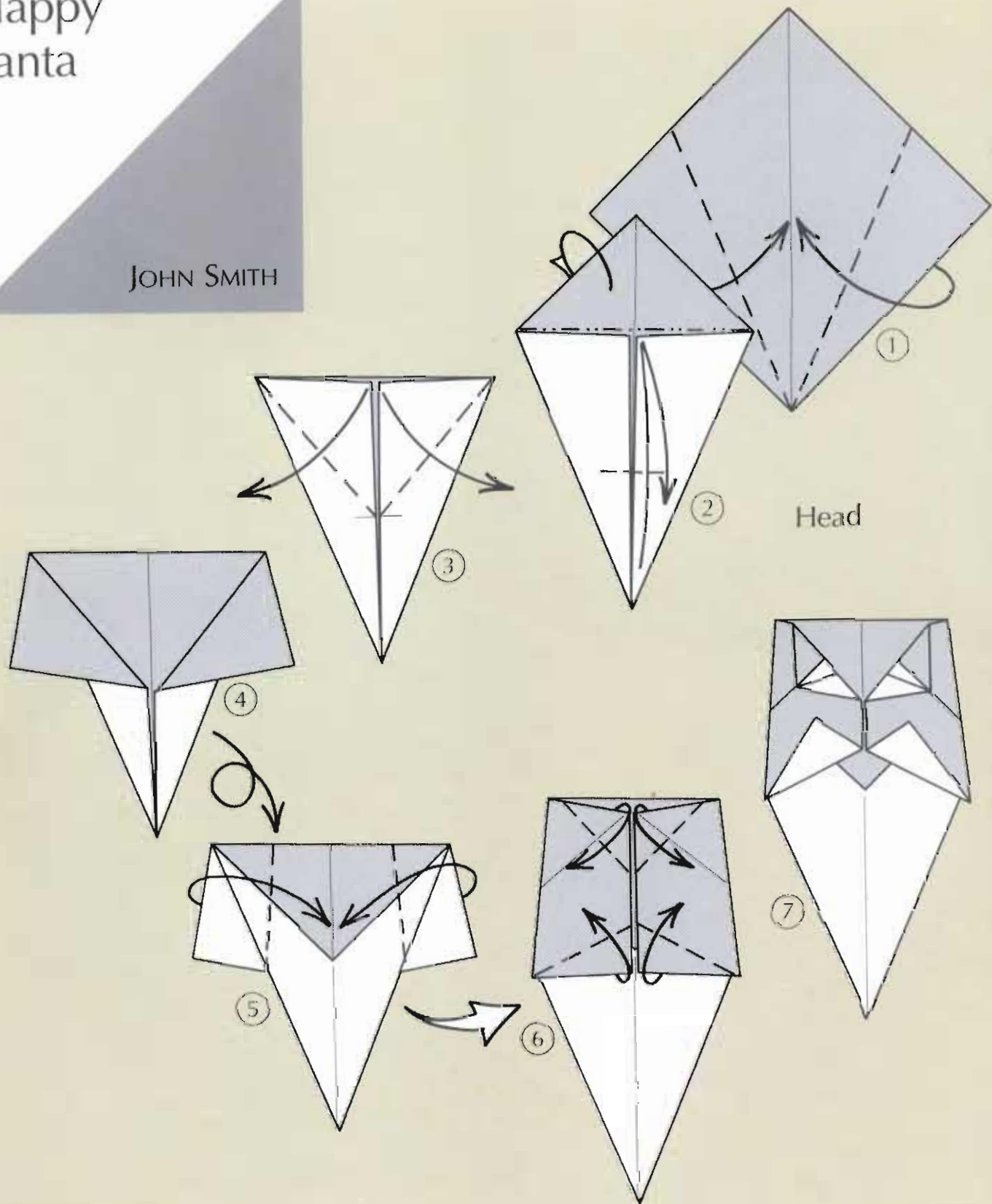

John Smith has developed many models using only mountain and valley folds. By using only these two types of folds he created a series of simple models to which he gave the term "Pureland Origami". This Happy Santa was designed by John Smith in 1991 for his personal Christmas card.

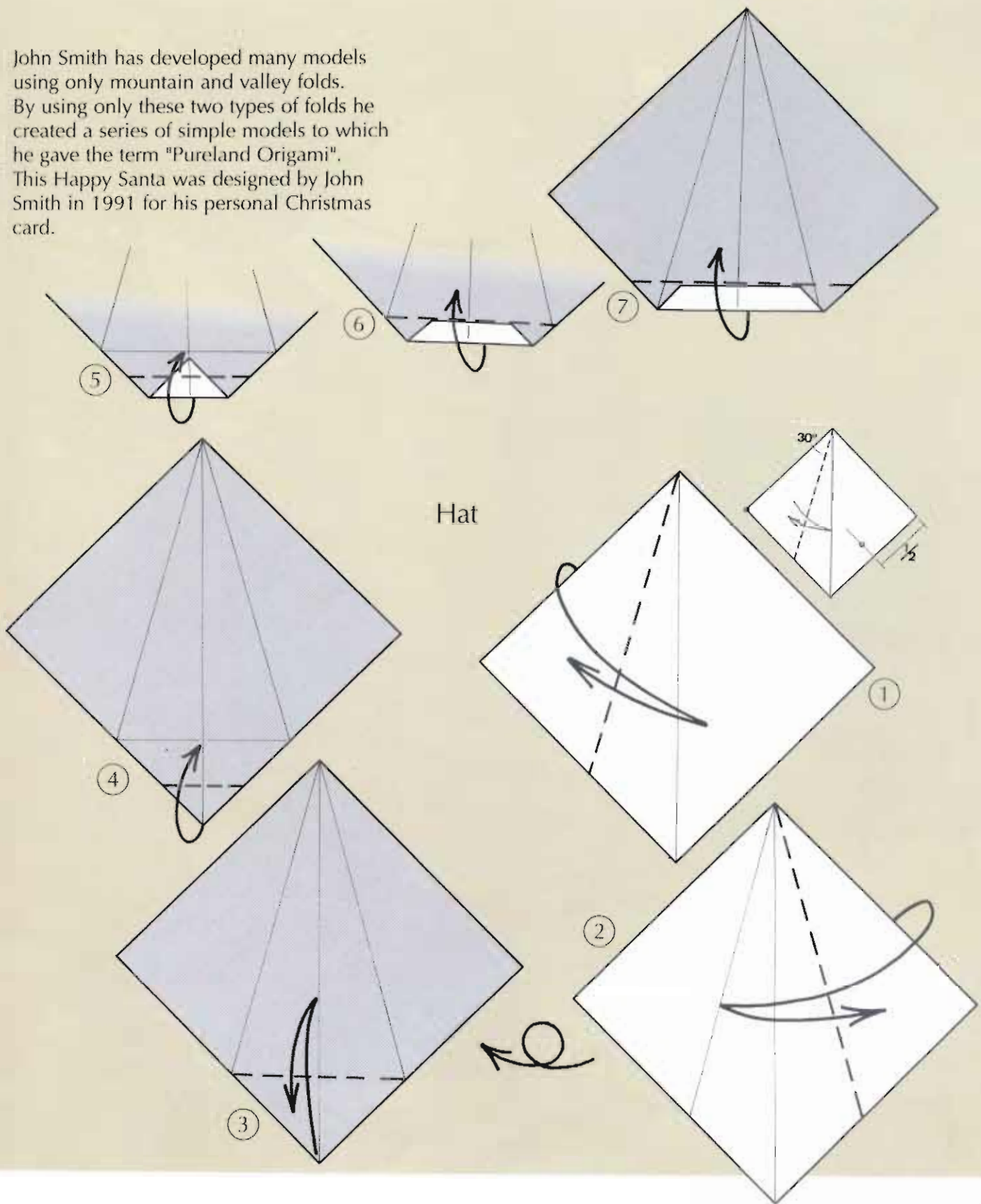

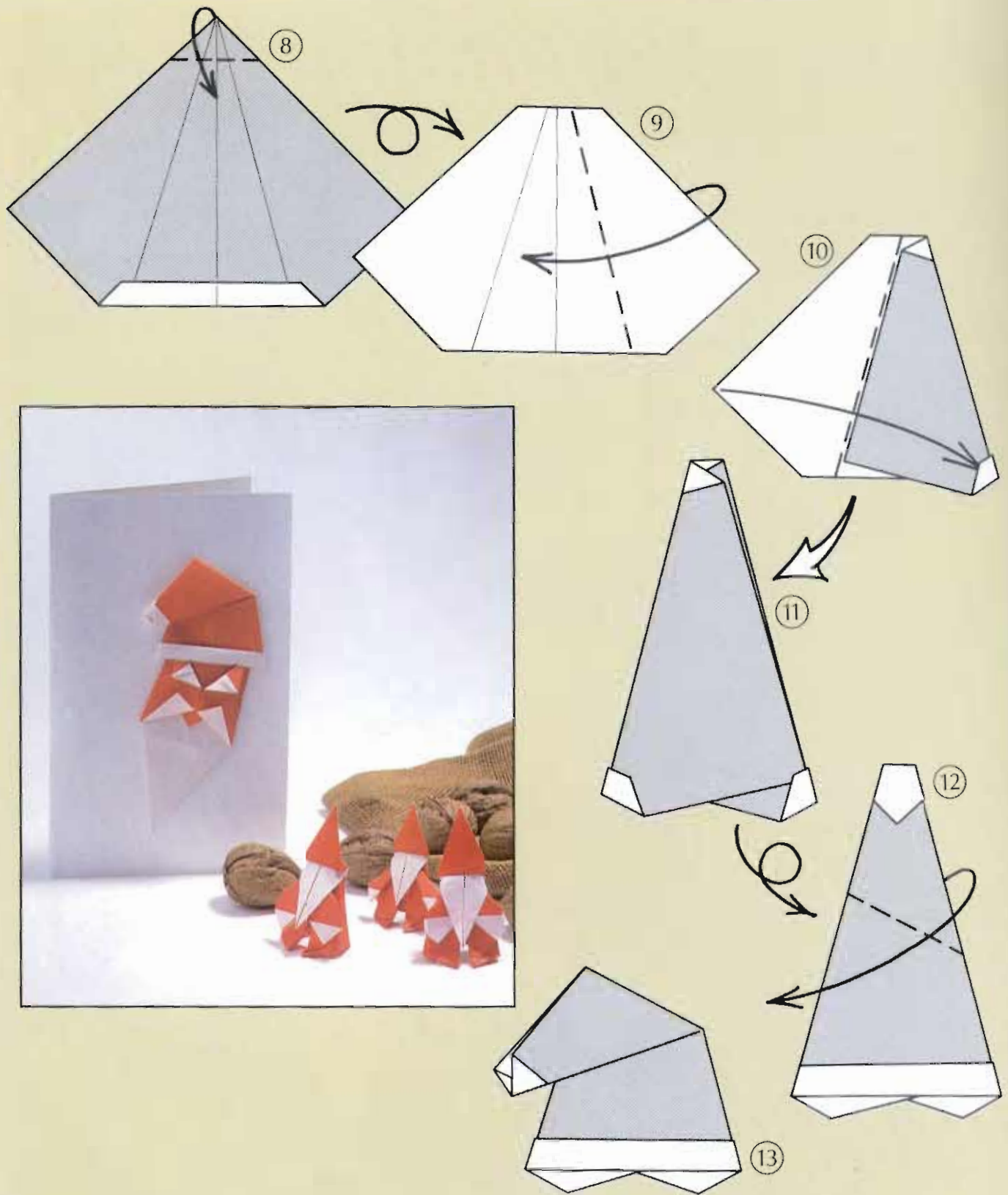

Geometric Figures



Cube

TOMOKO FUSE

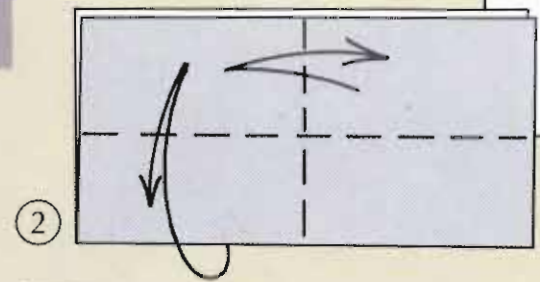
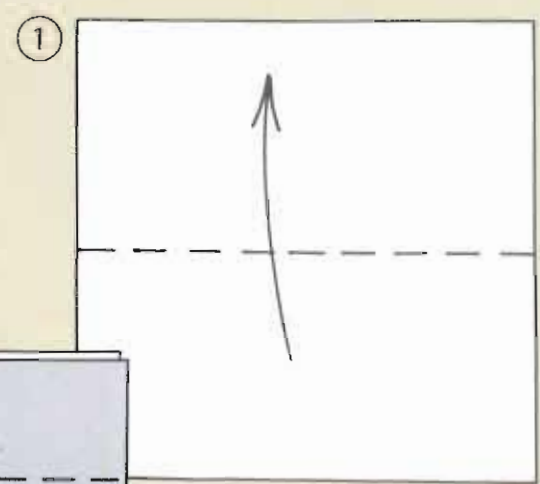

For this cube you need two separate elements which are mirror-images facing each other.

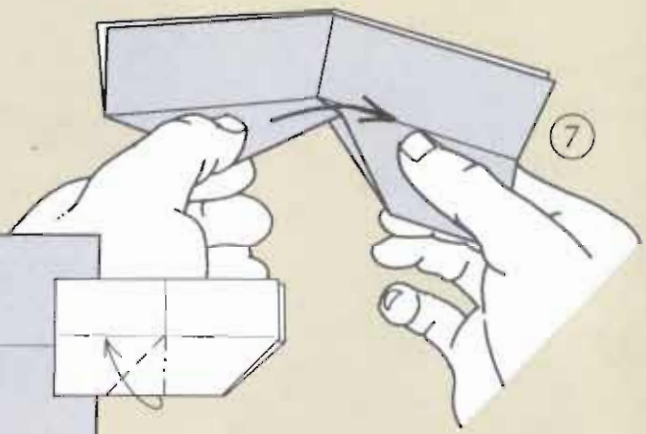
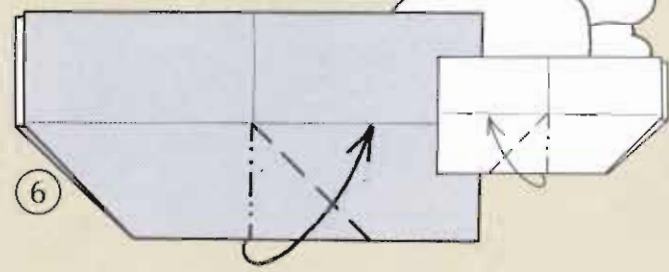
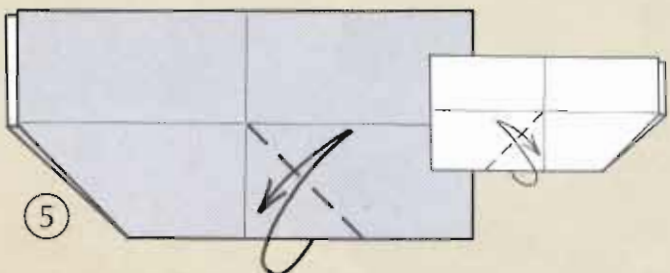
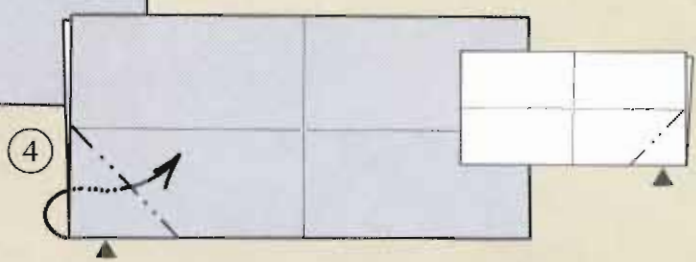
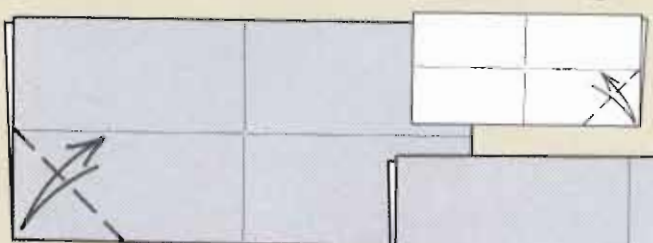

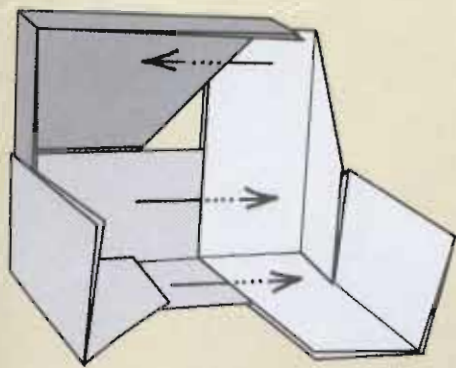

Corner B of one element should always be tucked into corner A of the other element. You will see that three corners C meet each time. Tuck each sharp side of a corner into the obtuse side of another corner.

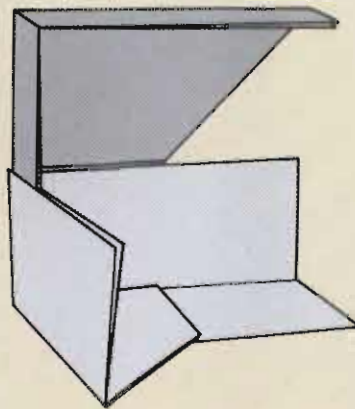

As with most geometric models, putting the last element in its place requires the most patience.

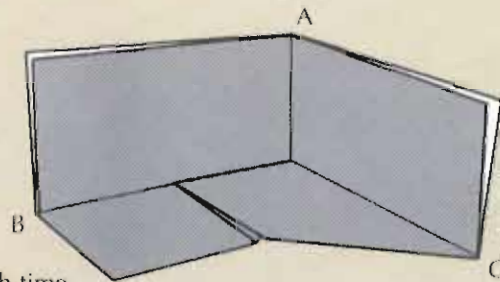
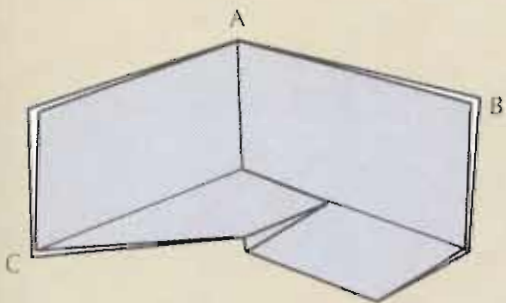

Fold three of these each time.

Open Cube

TOMOKO FUSE

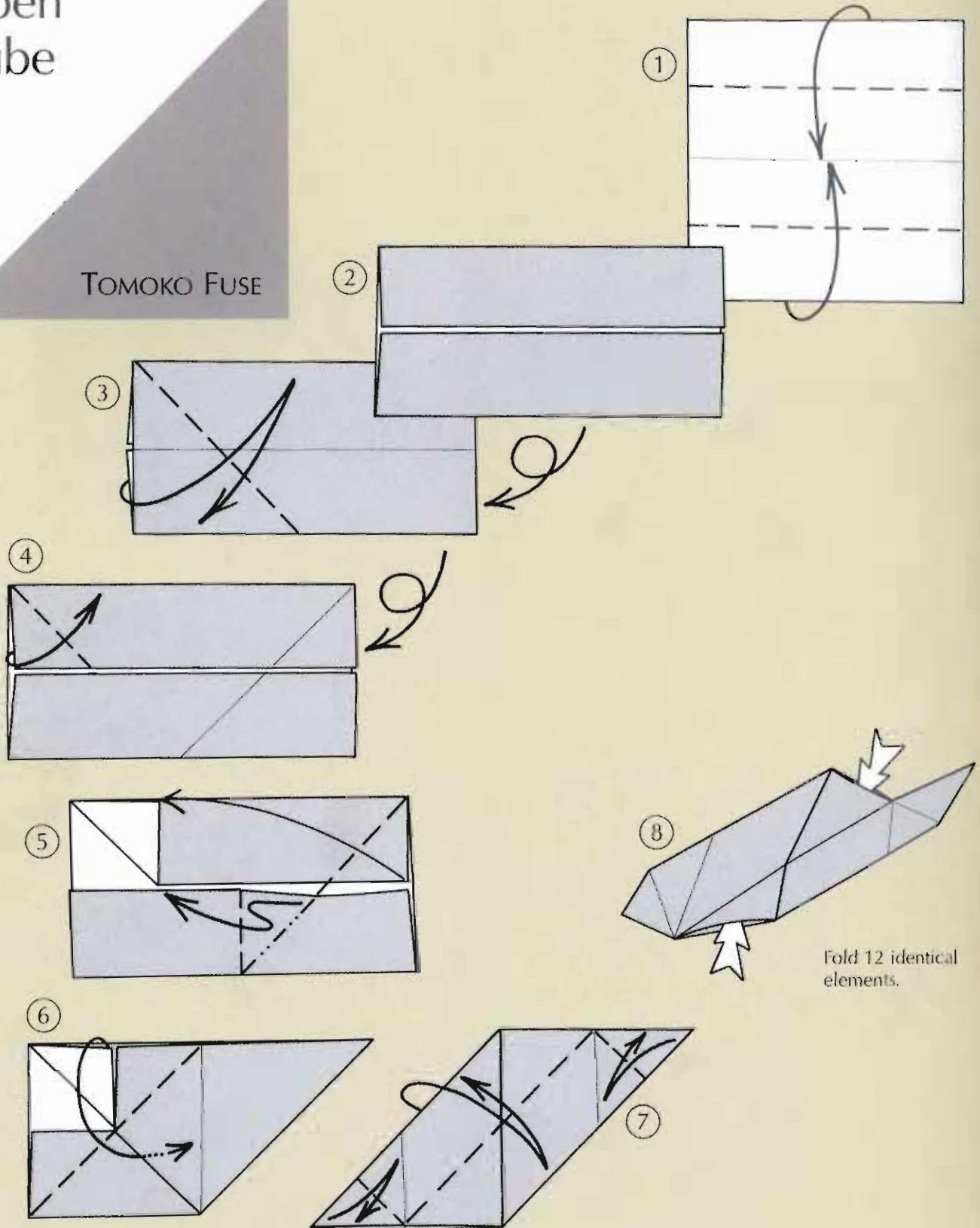

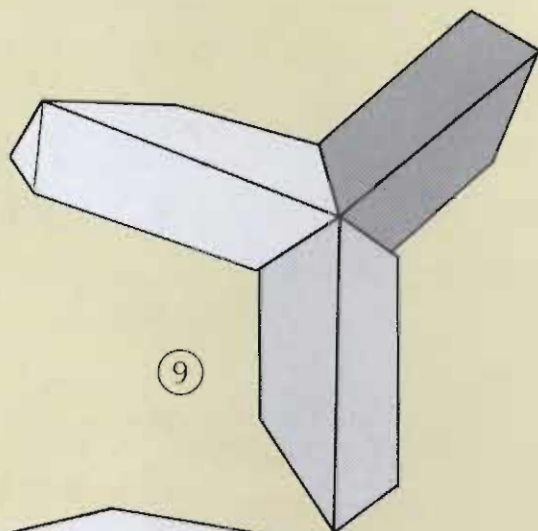
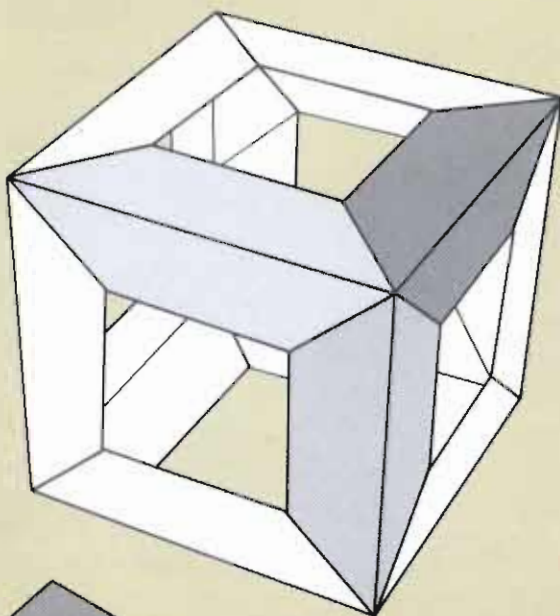

9

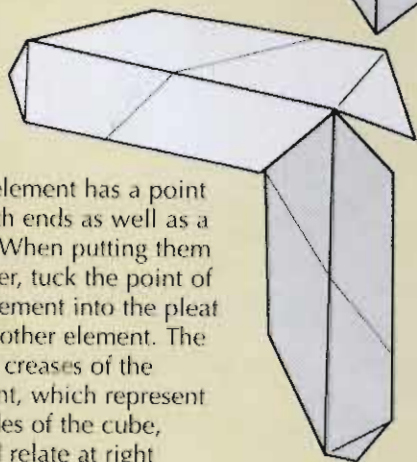

Each element has a point on both ends as well as a pleat. When putting them together, tuck the point of one element into the pleat of the other element. The center creases of the element, which represent the sides of the cube, should relate at right angles. A third element makes the connection complete.

The open cube inspires people to create many different combinations. The idea shown in the example was originated by Axel Reissnecker.

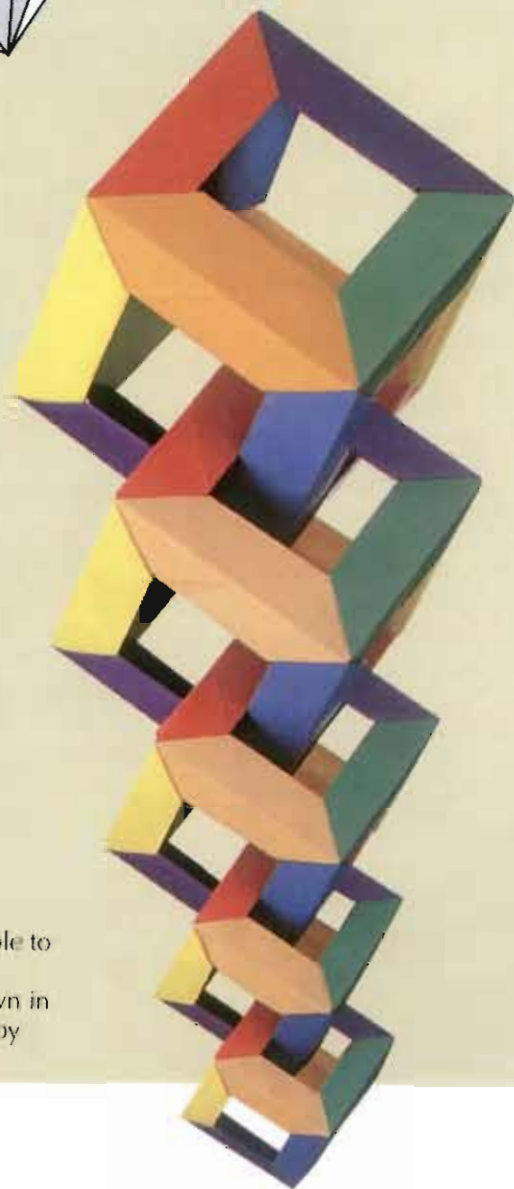

Sonobe Cube

MITSUNOBU SONOBE

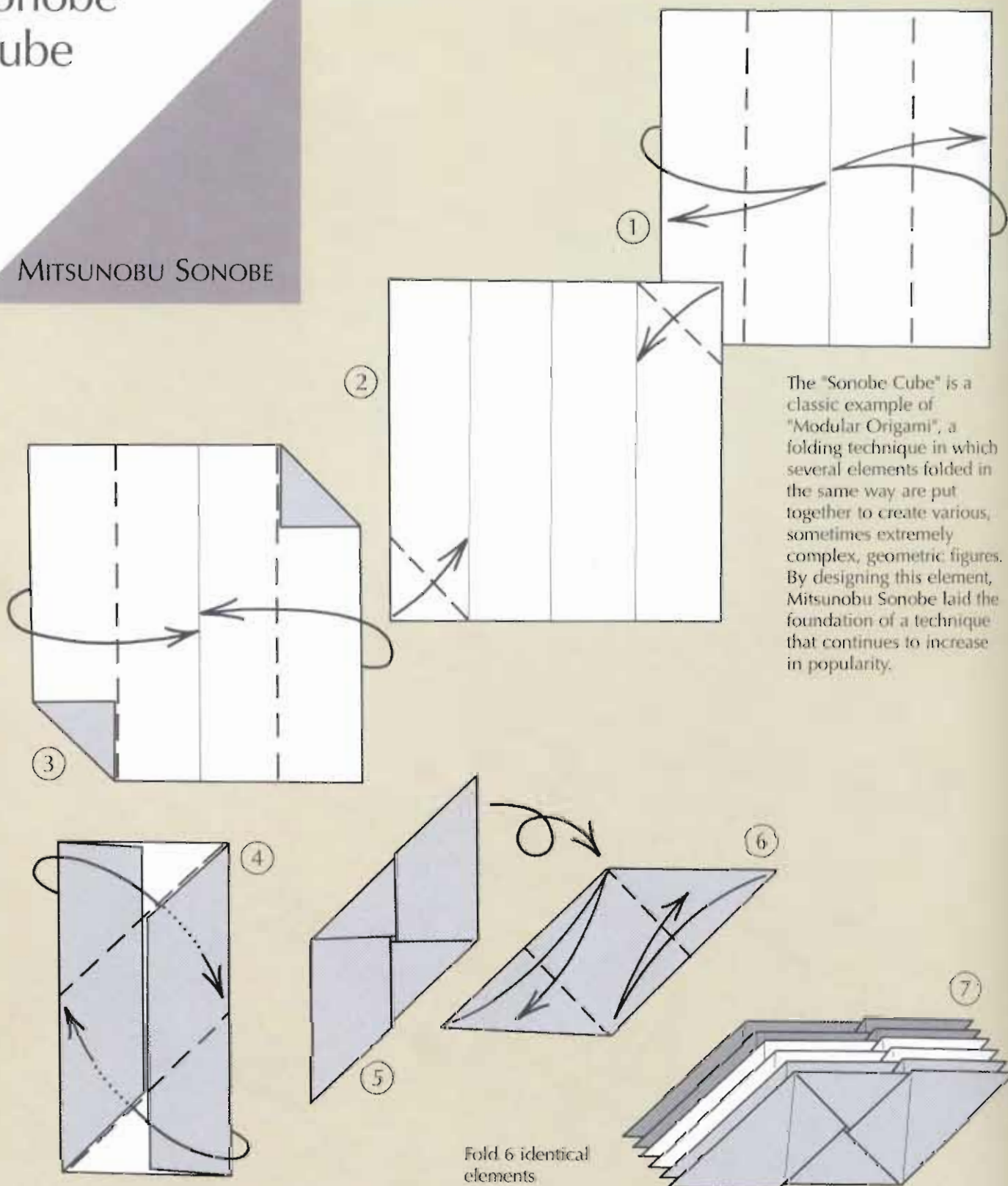

The "Sonobe Cube" is a classic example of "Modular Origami", a folding technique in which several elements folded in the same way are put together to create various, sometimes extremely complex, geometric figures. By designing this element, Mitsunobu Sonobe laid the foundation of a technique that continues to increase in popularity.

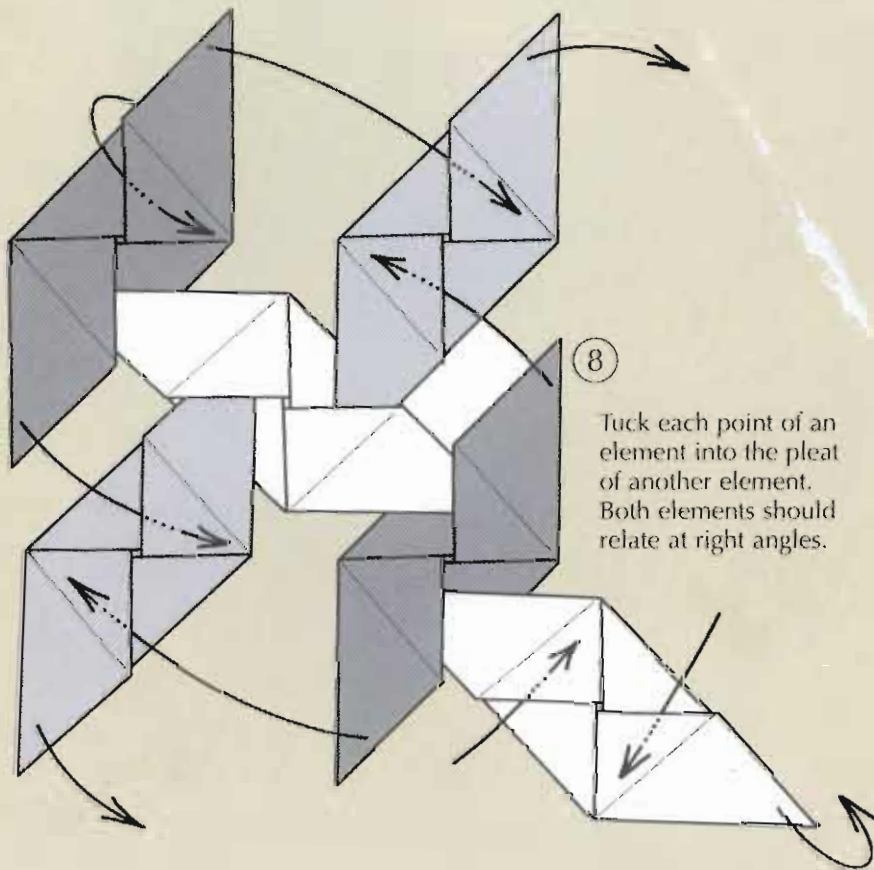
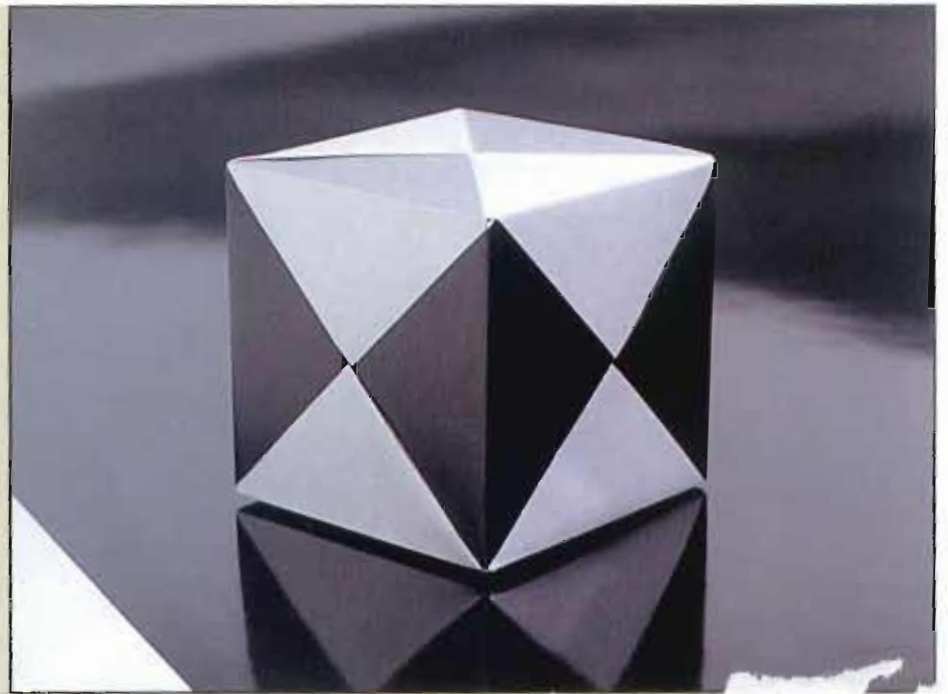

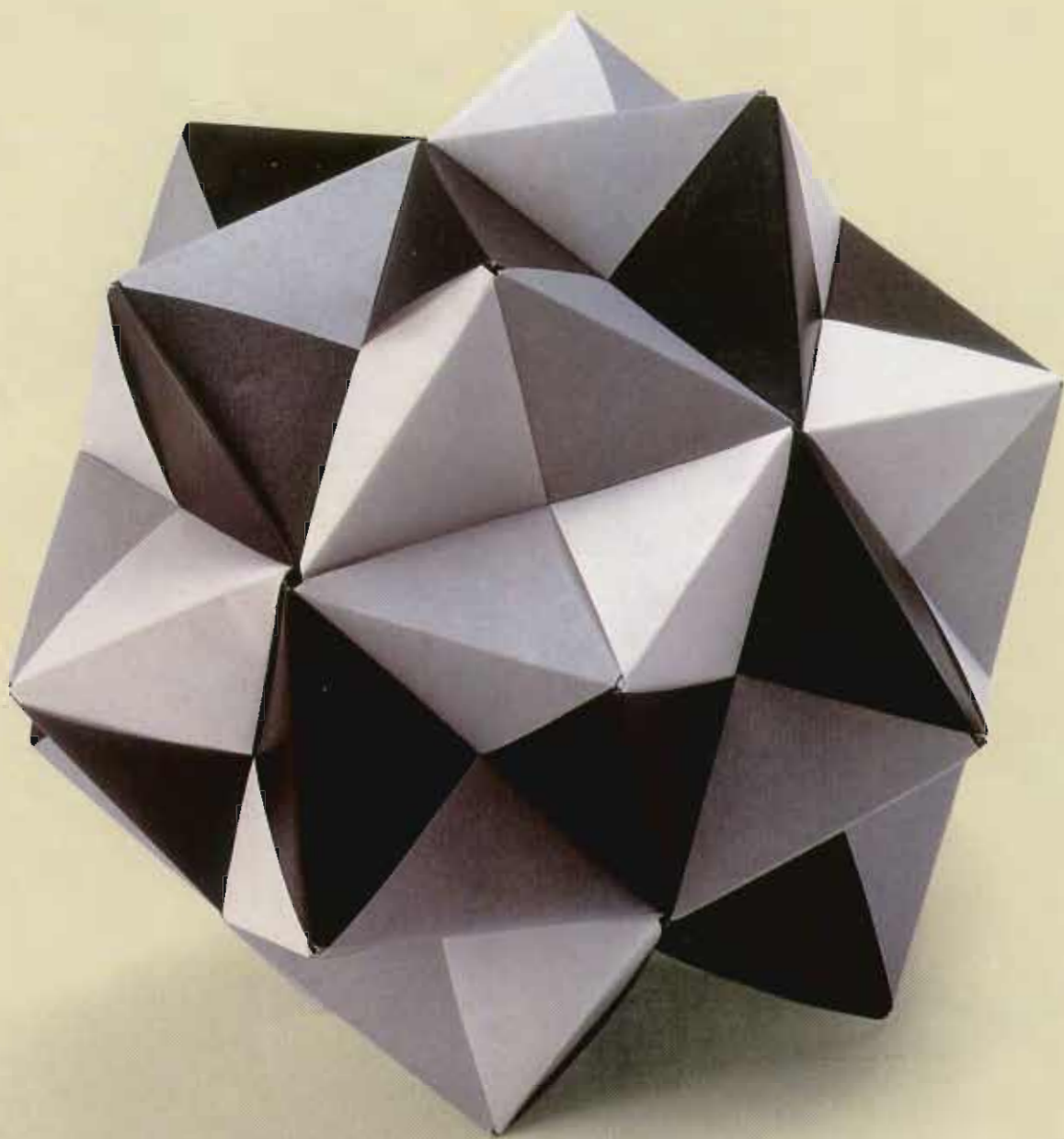

Organizations

Origami organizations can be found in almost every European country as well as in Japan and the USA.

These organizations provide information, advise on sources of supply, arrange meetings and often publish a magazine.



The models presented in this book originate from artists in England, Italy, USA, Spain, Denmark, Japan, Singapore and Hong Kong.

My admiration and gratitude go to them for allowing me to use their models in this book.

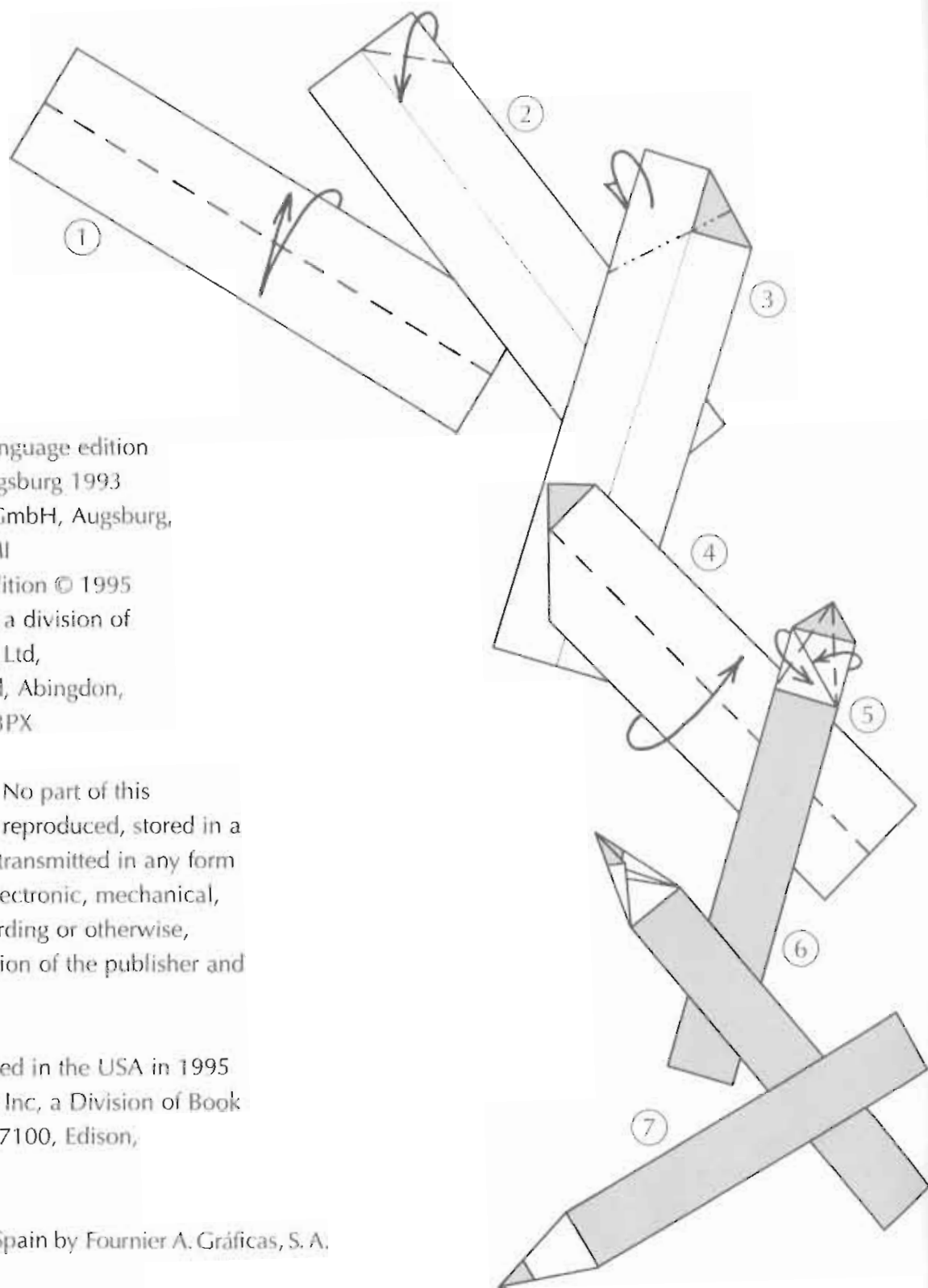

Original German-language edition
Augustus Verlag Augsburg 1993
© Weltbild Verlag GmbH, Augsburg,
PFIFFIGES ORIGAMI
English-language edition © 1995
Transedition Books, a division of
Andromeda Oxford Ltd,
11-15 The Vineyard, Abingdon,
Oxfordshire OX14 3PX

All rights reserved. No part of this
publication may be reproduced, stored in a
retrieval system, or transmitted in any form
or by any means, electronic, mechanical,
photocopying, recording or otherwise,
without the permission of the publisher and
copyright holders

This edition published in the USA in 1995
by Chartwell Books Inc, a Division of Book
Sales Inc, P.O. Box 7100, Edison,
N.J. 08818-7100

Printed in 1995 in Spain by Fournier A. Gráficas, S. A.

ISBN 0-7858-0262-2

ORIGAMI



How to make 30 amusing and attractive items from paper

This book describes the ancient art of Origami and shows fold by fold how you can learn the intricate and fascinating craft of paperfolding to create objects as diverse as a leaping frog, the amusing 'Shirt off one's back', a whole zoo of rabbits, mice,

elephants and pandas, Christmas decorations, picture frames, paper containers and folders, notebooks and envelopes.

These Origami classics and many others in this book have novelty and magic that will entertain you for hours.



0 39864 02622 2

ISBN 0-7858-0262-2



780785 802624

ISBN 0-7858-0262-4